

SITE CHARACTERISATION FORM

This form has been completed in accordance with the Code of
Practice:

WASTEWATER TREATMENT AND DISPOSAL SYSTEMS

CLIENT: Galway County Council

LOCATION: Lisdonagh, Headford, Co. Galway

DATE: 04/02/2026

Table of Contents

Page

Site Characterisation Form

1

Appendix A

Wells Map

15

Karst Map

15

Rivers and Lakes Map

16

Vulnerability Map

16

Aquifer Map

17

Soils Map

17

Bedrock Map

18

Groundwater Flow

18

Appendix B

Site Photographs

19

Appendix C

Packaged System and Section Drawing

22

Appendix D

QQI Award Certificate

42

SITE CHARACTERISATION FORM

COMPLETING THE FORM

Note: This form requires the latest version of Adobe Acrobat Reader and on PC's Windows 7 or later. Windows XP produces errors in calculations

Step 1:

Goto Menu Item **File, Save As** and save the file under a reference relating to the client or the planning application reference if available.

Clear Form

Use the **Clear Form** button to clear all information fields.

Notes:

All calculations in this form are automatic.

Where possible information is presented in the form of drop down selection lists to eliminate potential errors.

Variable elements are recorded by tick boxes. In all cases only one tick box should be activated.

All time record fields must be entered in twenty four hour format as follows: HH:MM

All date formats are DD-MM-YYYY.

All other data fields are in text entry format.

This form can be printed out fully populated for submission with related documents and for your files. It can also be submitted by email.

Section 3.2 In this section use an underline _____ across all six columns to indicate the depth at which changes in classification / characteristics occur.

Section 3.4 Lists supporting documentation required.

Section 4 Select the treatment systems suitable for this site and the discharge route.

Section 5 Indicate the system type that it is proposed to install.

Section 6 Provide details, as required, on the proposed treatment system.

APPENDIX A: SITE CHARACTERISATION FORM

File Reference:

1.0 GENERAL DETAILS (From planning application)

Prefix: First Name: Surname:

Address: Site Location and Townland:

Number of Bedrooms: Maximum Number of Residents:

Comments on population equivalent

Proposed Water Supply:

Mains Private Well/Borehole Group Well/Borehole

2.0 GENERAL DETAILS (From planning application)

Soil Type, (Specify Type):

Subsoil, (Specify Type):

Bedrock Type:

Aquifer Category: Regionally Important Rk | Locally Important Poor

Vulnerability: Extreme High Moderate Low

Groundwater Body: Status:

Name of Public/Group Scheme Water Supply within 1 km:

Source Protection Area: ZOC SI SO Groundwater Protection Response:

Presence of Significant Sites (Archaeological, Natural & Historical):

Past experience in the area:

Comments:

(Integrate the information above in order to comment on: the potential suitability of the site, potential targets at risk, and/or any potential site restrictions).

Potential Targets at Risk: Groundwater and Surface water will be at risk if minimum depths of suitable unsaturated permeable soil/subsoil above the water table or bedrock cannot be achieved.

The site is rated as having a High vulnerability and a Regionally Important Aquifer and has a Groundwater Protection Response of R21, which indicates that the site may be acceptable for on-site effluent treatment subject to the min depth of free draining subsoil present and favorable T/P values.

Depth of free draining subsoil is critical.

Note: Only information available at the desk study stage should be used in this section.

3.0 ON-SITE ASSESSMENT

3.1 Visual Assessment

Landscape Position:

Slope: Steep (>1:5) Shallow (1:5-1:20) Relatively Flat (<1:20)

Slope Comment

Surface Features within a minimum of 250m (Distance To Features Should Be Noted In Metres)

Houses:

Existing Land Use:

Vegetation Indicators:

Groundwater Flow Direction:

Ground Condition:

Site Boundaries:

3.0 ON-SITE ASSESSMENT

3.1 Visual Assessment (contd.)

Roads:

Local road to the North of the site

Outcrops (Bedrock And/Or Subsoil):

None within 500 meters

Surface Water Ponding:

None within 500 meters

Lakes:

Hackett Lake located 400m to the North East of the site

Beaches/Shellfish Areas:

None within 500 meters

Wetlands:

Wetland Area located to the North of the site

Karst Features:

Some Karst features located 450m to the South East of the site.

Watercourses/Streams:*

GORTARICA river located 100m to the east of the site.

*Note and record water level

3.0 ON-SITE ASSESSMENT

3.1 Visual Assessment (contd.)

Drainage Ditches:*

Open land drainage located 30m to the west of the site.

Springs:*

None within 500 meters

Wells:*

None within 500 meters

Comments:

(Integrate the information above in order to comment on: the potential suitability of the site, potential targets at risk, the suitability of the site to treat the wastewater and the location of the proposed system within the site).

Potential targets at risk:

Ground/surface water at risk where insufficient depth of free draining soil/subsoil is not found.

Fast percolation rates <3 where found would indicate an increased risk to groundwater.

Slow percolation rates >75 would indicate an increased risk of surface water ponding.

From visual inspection the site may be suitable for the effective treatment of domestic wastewater providing a favourable T/P value is achievable and sufficient unsaturated free draining soil depth is available.

*Note and record water level

3.2 Trial Hole (should be a minimum of 2.1m deep (3m for regionally important aquifers))

To avoid any accidental damage, a trial hole assessment or percolation tests should not be undertaken in areas which are at or adjacent to significant sites, (e.g. NHAs, SACs, SPAs, and/or Archaeological etc.), without prior advice from National Parks and Wildlife Service or the Heritage Service.

Depth of trial hole (m):

Depth from ground surface to bedrock (m) (if present):

Depth from ground surface to water table (m) (if present):

Depth of water ingress:

Rock type (if present):

Date and time of excavation:

Date and time of examination:

Depth of Surface and Subsurface

Percolation Tests	Soil/Subsoil Texture & Classification**	Plasticity and dilatancy***	Soil Structure	Density/ Compactness	Colour****	Preferential flowpaths
0.1 m <input type="text"/>	Clay		Crumb	firm	Dark Brown	Rootlets
0.2 m <input type="text"/>						
0.3 m <input type="text"/>						
0.4 m <input type="text"/>						
0.5 m <input type="text"/>						
0.6 m <input type="text"/>						
0.7 m <input type="text"/>						
0.8 m <input type="text"/>	Thick beeded clay with some gravels	Threads = 6 Avg Ribbons = 140 Dilatant = difficulty	Blocky	Firm/Medium	Brown	None
0.9 m <input type="text"/>						
1.0 m <input type="text"/>						
1.1 m <input type="text"/>						
1.2 m <input type="text" value="W.T."/>						
1.3 m <input type="text"/>	Water Table	Water Table	Water Table	Water Table	Water Table	Water Table
1.4 m <input type="text"/>						
1.5 m <input type="text"/>						
1.6 m <input type="text"/>						
1.7 m <input type="text"/>						
1.8 m <input type="text"/>						
1.9 m <input type="text"/>						
2.0 m <input type="text"/>						
2.1 m <input type="text"/>						
2.2 m <input type="text"/>						
2.3 m <input type="text"/>						
2.4 m <input type="text"/>						
2.5 m <input type="text"/>						
2.6 m <input type="text"/>						
2.7 m <input type="text"/>						
2.8 m <input type="text"/>						
2.9 m <input type="text"/>						
3.0 m <input type="text"/>						
3.1 m <input type="text"/>						
3.2 m <input type="text"/>						
3.3 m <input type="text"/>						
3.4 m <input type="text"/>						
3.5 m <input type="text"/>						

Likely Subsurface Percolation Value:

Likely Surface Percolation Value:

Note: *Depth of percolation test holes should be indicated on log above. (*Enter Surface or Subsurface at depths as appropriate).
 ** See Appendix E for BS 5930 classification.
 *** 3 samples to be tested for each horizon and results should be entered above for each horizon.
 **** All signs of mottling should be recorded.

3.2 Trial Hole (contd.) Evaluation:

--

3.3(a) Subsurface Percolation Test for Subsoil

Step 1: Test Hole Preparation

Percolation Test Hole

	1	2	3
Depth from ground surface to top of hole (mm) (A)	400	400	400
Depth from ground surface to base of hole (mm) (B)	800	800	800
Depth of hole (mm) [B - A]	400	400	400
Dimensions of hole [length x breadth (mm)]	300 x 300	300 x 300	300 x 300

Step 2: Pre-Soaking Test Holes

Pre-soak start	Date	25-Jan-2026	25-Jan-2026	25-Jan-2026
	Time	10:00	10:00	10:00
2nd pre-soak start	Date	25-Jan-2026	25-Jan-2026	25-Jan-2026
	Time	14:00	14:00	14:00

Each hole should be pre-soaked twice before the test is carried out.

Step 3: Measuring T_{100}

Percolation Test Hole No.

	1	2	3	
Date of test	26-01-2026	26-01-2026	26-01-2026	
Time filled to 400 mm	09:30	09:30	09:30	
Time water level at 300 mm	10:52	10:45	10:58	
Time (min.) to drop 100 mm (T_{100})	82.00	75.00	88.00	
Average T_{100}				81.67

If $T_{100} > 480$ minutes then Subsurface Percolation value >120 – site unsuitable for discharge to ground

If $T_{100} \leq 210$ minutes then go to Step 4;

If $T_{100} > 210$ minutes then go to Step 5;

Step 4: Standard Method (where $T_{100} \leq 210$ minutes)

Percolation Test Hole	1			2			3		
Fill no.	Start Time (at 300 mm)	Finish Time (at 200 mm)	Δt (min)	Start Time (at 300 mm)	Finish Time (at 200 mm)	Δt (min)	Start Time (at 300 mm)	Finish Time (at 200 mm)	Δt (min)
1	10:52	12:22	90.00	10:45	12:15	90.00	10:58	12:36	98.00
2	12:23	14:23	120.00	12:16	14:36	140.00	12:37	14:28	111.00
3	14:24	16:35	131.00	14:37	17:25	168.00	14:29	17:18	169.00
Average Δt Value	113.67			132.67			126.00		
	Average $\Delta t/4 =$ [Hole No.1] <input type="text" value="28.42"/> (t_1)			Average $\Delta t/4 =$ [Hole No.2] <input type="text" value="33.17"/> (t_2)			Average $\Delta t/4 =$ [Hole No.3] <input type="text" value="31.50"/> (t_3)		

Result of Test: Subsurface Percolation Value = (min/25 mm)

Comments:

Test passed.

Step 5: Modified Method (where $T_{100} > 210$ minutes)

Percolation Test Hole No.	1					
Fall of water in hole (mm)	Time Factor = T_f	Start Time hh:mm	Finish Time hh:mm	Time of fall (mins) = T_m	$K_{fs} = T_f / T_m$	T - Value = $4.45 / K_{fs}$
300 - 250	8.1			0.00		
250 - 200	9.7			0.00		
200 - 150	11.9			0.00		
150 - 100	14.1			0.00		
Average	T- Value	T- Value Hole 1 = (T_1)		<input type="text" value="0.00"/>		

Percolation Test Hole No.	2					
Fall of water in hole (mm)	Time Factor = T_f	Start Time hh:mm	Finish Time hh:mm	Time of fall (mins) = T_m	$K_{fs} = T_f / T_m$	T - Value = $4.45 / K_{fs}$
300 - 250	8.1			0.00		
250 - 200	9.7			0.00		
200 - 150	11.9			0.00		
150 - 100	14.1			0.00		
Average	T- Value	T- Value Hole 2 = (T_2)		<input type="text" value="0.00"/>		

Result of Test: Subsurface Percolation Value =

(min/25 mm)

Percolation Test Hole No.	3					
Fall of water in hole (mm)	Time Factor = T_f	Start Time hh:mm	Finish Time hh:mm	Time of fall (mins) = T_m	$K_{fs} = T_f / T_m$	T - Value = $4.45 / K_{fs}$
300 - 250	8.1			0.00		
250 - 200	9.7			0.00		
200 - 150	11.9			0.00		
150 - 100	14.1			0.00		
Average	T- Value	T- Value Hole 3 = (T_3)		<input type="text" value="0.00"/>		

Comments:

3.3(b) Surface Percolation Test for Soil

Step 1: Test Hole Preparation

Percolation Test Hole	1	2	3
Depth from ground surface to top of hole (mm)	0	0	0
Depth from ground surface to base of hole (mm)	400	400	400
Depth of hole (mm)	400	400	400
Dimensions of hole [length x breadth (mm)]	300 x 300	300 x 300	300 x 300

Step 2: Pre-Soaking Test Holes

Pre-soak start	Date	25-Jan-2026	25-Jan-2026	25-Jan-2026
	Time	10:00	10:00	10:00
2nd pre-soak start	Date	25-Jan-2026	25-Jan-2026	25-Jan-2026
	Time	14:00	14:00	14:00

Each hole should be pre-soaked twice before the test is carried out.

Step 3: Measuring T_{100}

Percolation Test Hole No.	1	2	3
Date of test	26-Jan-26	26-Jan-26	26-Jan-2026
Time filled to 400 mm	09:30	09:30	09:30
Time water level at 300 mm	11:06	11:18	11:04
Time to drop 100 mm (T_{100})	96.00	108.00	94.00
Average T_{100}			99.33

If $T_{100} > 480$ minutes then Surface Percolation value >90 – site unsuitable for discharge to ground

If $T_{100} \leq 210$ minutes then go to Step 4;

If $T_{100} > 210$ minutes then go to Step 5;

Step 4: Standard Method (where $T_{100} \leq 210$ minutes)

Percolation Test Hole	1			2			3								
	Start Time (at 300 mm)	Finish Time (at 200 mm)	ΔT (min)	Start Time (at 300 mm)	Finish Time (at 200 mm)	ΔT (min)	Start Time (at 300 mm)	Finish Time (at 200 mm)	ΔT (min)						
1	11:06	12:58	112.00	11:18	12:57	99.00	11:04	12:36	92.00						
2	12:59	14:38	99.00	12:58	14:56	118.00	12:37	14:34	117.00						
3	14:39	16:32	113.00	14:57	17:14	137.00	14:35	16:49	134.00						
Average ΔT Value	108.00			118.00			114.33								
Average $\Delta T/4 =$ [Hole No.1]	27.00 (T_1)			Average $\Delta T/4 =$ [Hole No.2]			29.50 (T_2)			Average $\Delta T/4 =$ [Hole No.3]			28.58 (T_3)		

Result of Test: Surface Percolation Value = (min/25 mm)

Comments:

P test passed

Step 5: Modified Method (where $T_{100} > 210$ minutes)

Percolation Test Hole No.	1					
	Time Factor = T_f	Start Time hh:mm	Finish Time hh:mm	Time of fall (mins) = T_m	$K_{fs} = T_f / T_m$	T-Value = $4.45 / K_{fs}$
300 - 250	8.1			0.00		
250 - 200	9.7			0.00		
200 - 150	11.9			0.00		
150 - 100	14.1			0.00		
Average	T- Value	T- Value Hole 1 = (T_1)		<input type="text" value="0.00"/>		

Percolation Test Hole No.	2					
	Time Factor = T_f	Start Time hh:mm	Finish Time hh:mm	Time of fall (mins) = T_m	$K_{fs} = T_f / T_m$	T-Value = $4.45 / K_{fs}$
300 - 250	8.1			0.00		
250 - 200	9.7			0.00		
200 - 150	11.9			0.00		
150 - 100	14.1			0.00		
Average	T- Value	T- Value Hole 2 = (T_2)		<input type="text" value="0.00"/>		

Result of Test: Surface Percolation Value =

(min/25 mm)

Percolation Test Hole No.	3					
	Time Factor = T_f	Start Time hh:mm	Finish Time hh:mm	Time of fall (mins) = T_m	$K_{fs} = T_f / T_m$	T-Value = $4.45 / K_{fs}$
300 - 250	8.1			0.00		
250 - 200	9.7			0.00		
200 - 150	11.9			0.00		
150 - 100	14.1			0.00		
Average	T- Value	T- Value Hole 3 = (T_3)		<input type="text" value="0.00"/>		

Comments:

3.4 The following associated Maps, Drawings and Photographs should be appended to this site characterisation form.

1. Discovery Series 1:50,000 Map indicating overall drainage, groundwater flow direction and housing density in the area.
2. Supporting maps for vulnerability, aquifer classification, soil, subsoil, bedrock.
3. North point should always be included.
4. (a) Scaled sketch of site showing measurements to Trial Hole location and
 - (b) Percolation Test Hole locations,
 - (c) wells and
 - (d) direction of groundwater flow (if known),
 - (e) proposed house (incl. distances from boundaries)
 - (f) adjacent houses,
 - (g) watercourses,
 - (h) significant sites
 - (i) and other relevant features.
5. Site specific cross sectional drawing of the site and the proposed layout¹ should be submitted.
6. Photographs of the trial hole, test holes and site including landmarks (date and time referenced).
7. Pumped design must be designed by a suitably qualified person.

¹ The calculated percolation area or polishing filter area should be set out accurately on the site layout drawing in accordance with the code of practice's requirements.

4.0 CONCLUSION of SITE CHARACTERISATION

Integrate the information from the desk study and on-site assessment (i.e. visual assessment, trial hole and percolation tests) above and conclude the type of system(s) that is (are) appropriate. This information is also used to choose the optimum final disposal route of the treated wastewater.

Slope of proposed infiltration / treatment area:

Are all minimum separation distances met?

Depth of unsaturated soil and/or subsoil beneath invert of gravel (or drip tubing in the case of drip dispersal system)

Percolation test result: Surface:

Sub-surface:

Not Suitable for Development

Suitable for Development

Identify all suitable options

1. Septic tank system (septic tank and percolation area) (**Chapter 7**)
2. Secondary Treatment System (**Chapters 8 and 9**) and soil polishing filter (**Section 10.1**)
3. Tertiary Treatment System and Infiltration / treatment area (**Section 10.2**)

Discharge Route ¹

Discharge to Ground Water

5.0 SELECTED DWWTs

Propose to install:

and discharge to:

Invert level of the trench/bed gravel or drip tubing (m)

Site Specific Conditions (e.g. special works, site improvement works testing etc.

IT IS RECOMMENDED TO INSTALL A PACKAGED WASTEWATER TREATMENT SYSTEM AND A TERTIARY COCO FILTER

With a high winter water table it is proposed to install a secondary waste water treatment system and then treated by a Coco Filter unit . The effluent from the tertiary unit will be distributed to a 45sqm 300mm deep gravel distribution area which will be beneath the packaged tertiary treatment system. This 300mm Gravel layer will be located on top of the existing ground level. The Gravel layer be constructed using pea gravel, 300 mm deep gravel distribution area (pea gravel, 12–32 mm), sized according to Option 6 in Table 10.1 of the COP.

The separation distances need to be adhered to as per table 6.1 in the code of practice.

¹ A discharge of sewage effluent to "waters" (definition includes any or any part of any river, stream, lake, canal, reservoir, aquifer, pond, watercourse or other inland waters, whether natural or artificial) will require a licence under the Water Pollution Acts 1977-90. Refer to Section 2.4.

6.0 TREATMENT SYSTEM DETAILS

SYSTEM TYPE: Septic Tank Systems (Chapter 7)

Tank Capacity (m ³)	<input type="text"/>	Percolation Area	<input type="text"/>	Mounded Percolation Area	<input type="text"/>
		No. of Trenches	<input type="text"/>	No. of Trenches	<input type="text"/>
		Length of Trenches (m)	<input type="text"/>	Length of Trenches (m)	<input type="text"/>
		Invert Level (m)	<input type="text"/>	Invert Level (m)	<input type="text"/>

SYSTEM TYPE: Secondary Treatment System (Chapters 8 and 9) and polishing filter (Section 10.1)

Secondary Treatment Systems receiving septic tank effluent (Chapter 8)

Media Type	Area (m ²)*	Depth of Filter	Invert Level
Sand/Soil	<input type="text"/>	<input type="text"/>	<input type="text"/>
Soil	<input type="text"/>	<input type="text"/>	<input type="text"/>
Constructed Wetland	<input type="text"/>	<input type="text"/>	<input type="text"/>
Other	<input type="text"/>	<input type="text"/>	<input type="text"/>

Packaged Secondary Treatment Systems receiving raw wastewater (Chapter 9)

Type	<input type="text" value="Graf One 2 Clean"/>
Capacity PE	<input type="text" value="7"/>
Sizing of Primary Compartment	<input type="text" value="4.00"/> m ³

Polishing Filter*: (Section 10.1)

Surface Area (m ²)*	<input type="text"/>	Option 3 - Gravity Discharge Trench length (m)	<input type="text"/>
Option 1 - Direct Discharge Surface area (m ²)	<input type="text"/>	Option 4 - Low Pressure Pipe Distribution Trench length (m)	<input type="text"/>
Option 2 - Pumped Discharge Surface area (m ²)	<input type="text"/>	Option 5 - Drip Dispersal Surface area (m ²)	<input type="text"/>

SYSTEM TYPE: Tertiary Treatment System and infiltration / treatment area (Section 10.2)

Identify purpose of tertiary treatment

to further improve the effluent quality before it is discharged to the receiving environment.

Provide performance information demonstrating system will provide required treatment levels

Wastewater discharge from the Filter will be treated to a 10:10:10 standard or better (BOD:SS:Amn)

Provide design information

The coco fragment based filtering media is where water is organically further treated and filtered where pollutants are retained and degraded

DISCHARGE ROUTE:

Groundwater	<input checked="" type="checkbox"/>	Hydraulic Loading Rate * (l/m ² .d)	<input type="text"/>	Surface area (m ²)	<input type="text"/>
Surface Water **	<input type="checkbox"/>	Discharge Rate (m ³ /hr)	<input type="text"/>		

* Hydraulic loading rate is determined by the percolation rate of subsoil

** Water Pollution Act discharge licence required

6.0 TREATMENT SYSTEM DETAILS

QUALITY ASSURANCE:

Installation & Commissioning

THE TREATMENT UNIT SHALL BE INSTALLED IN ACCORDANCE THE REQUIREMENTS OUTLINED IN THE EPA CODE OF PRACTICE - WASTEWATER TREATMENT AND DISPOSAL SYSTEMS SERVING SINGLE HOUSES 2021. COMMISSIONING BY MANUFACTURES REPERSENTIVE.

On-going Maintenance

DE-SLUDGING SHALL BE CARRIED OUT A MINIMUM OF ONCE PER YEAR AND IN ACCORDANCE THE REQUIREMENTS OUTLINED IN TABLE 12.2 IN THE EPA CODE OF PRACTICE - WASTEWATER TREATMENT AND DISPOSAL SYSTEMS SERVING SINGLE HOUSES 2021.

7.0 SITE ASSESSOR DETAILS

Company:

Prefix: Mr First Name: Surname:

Address:

Qualifications/Experience:

Date of Report:

Phone: E-mail:

Indemnity Insurance Number:

Signature: Paul Roche

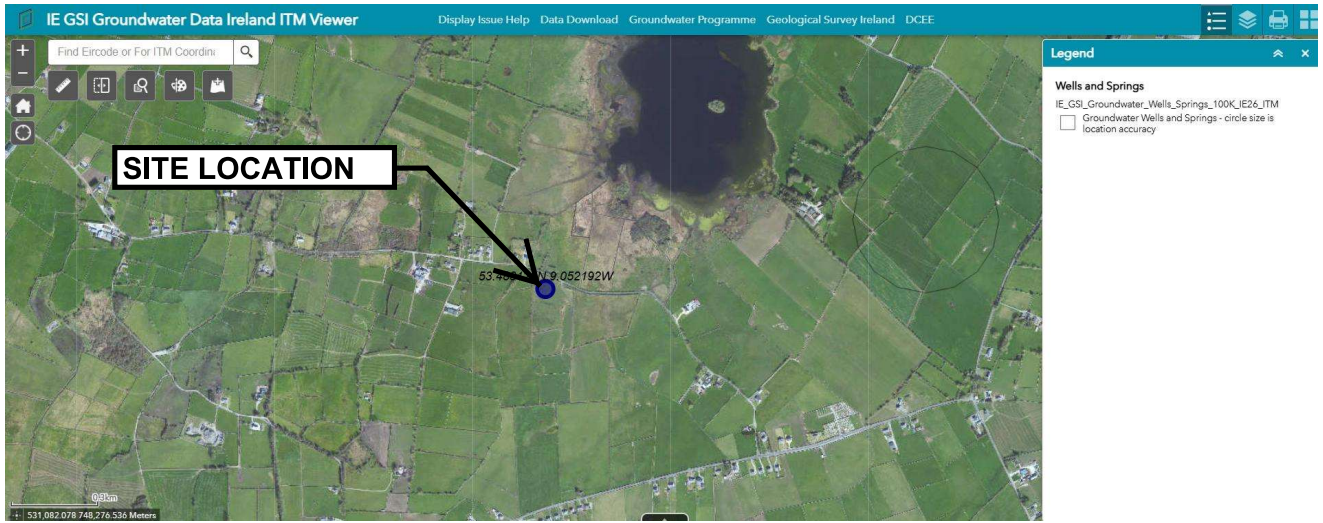

WELLS MAP



KARST MAP

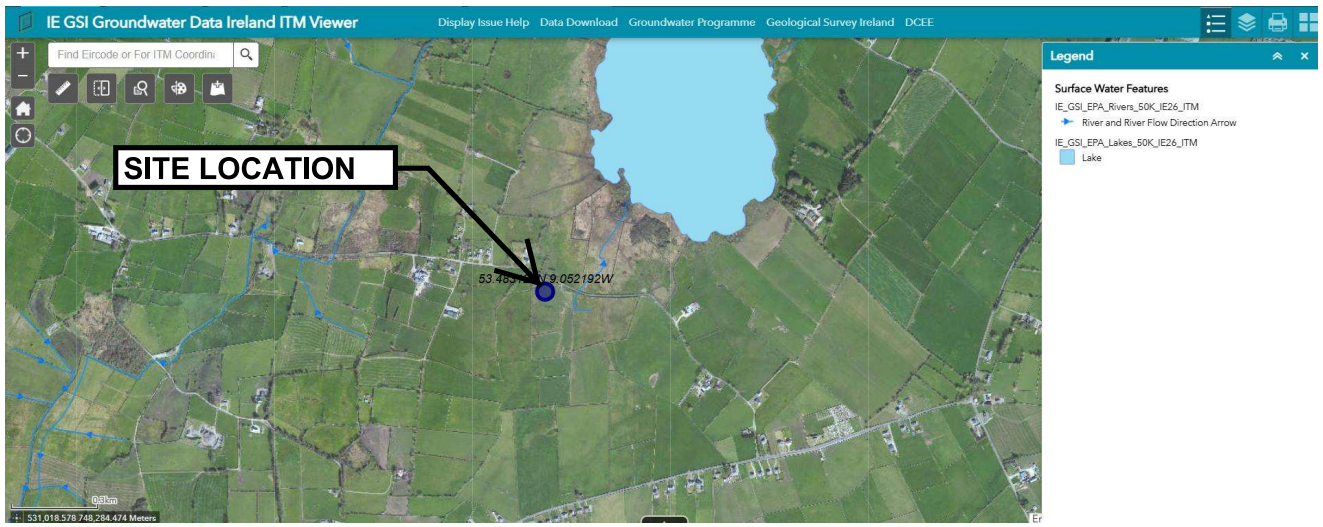

RIVERS AND LAKES MAP



VULNERABILITY MAP

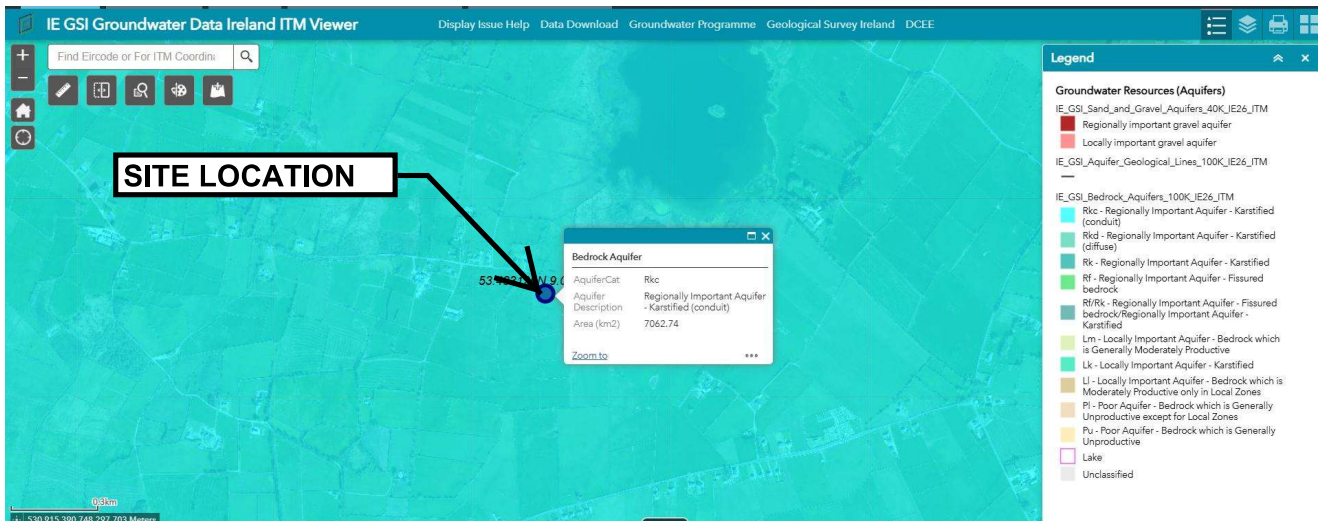

AQUIFER MAP

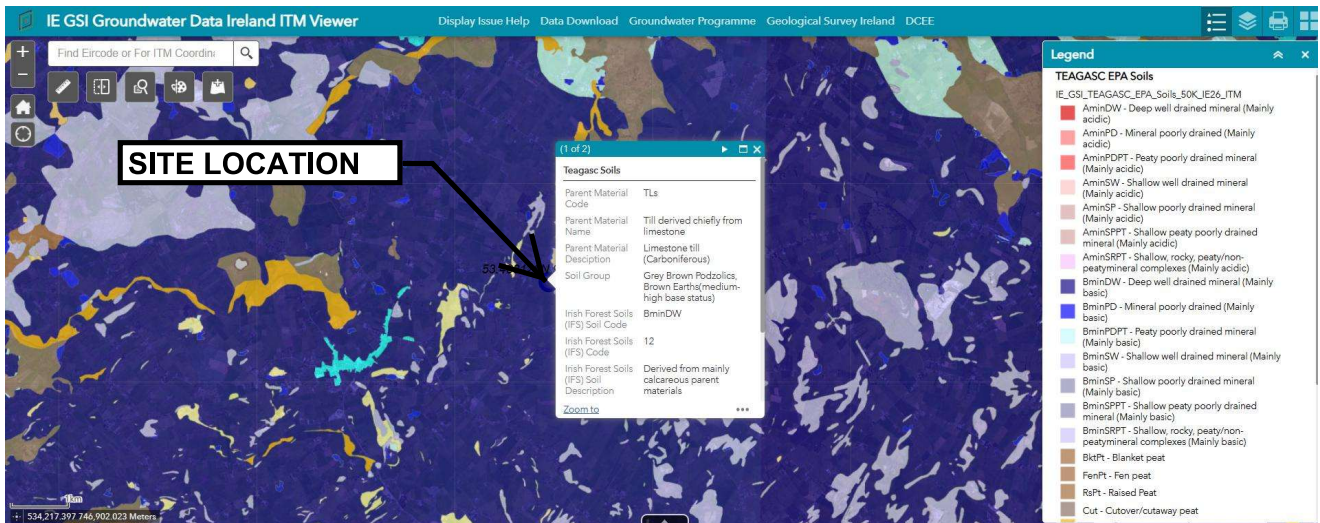

SOILS MAP

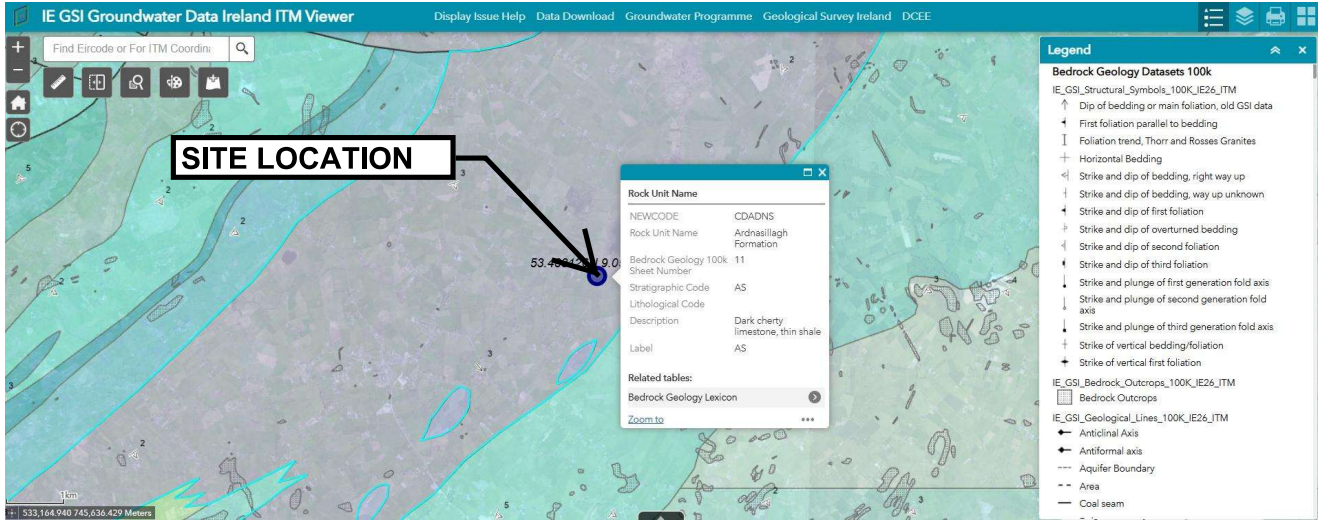

BEDROCK MAP



GROUNDWATER FLOW DIRECTION

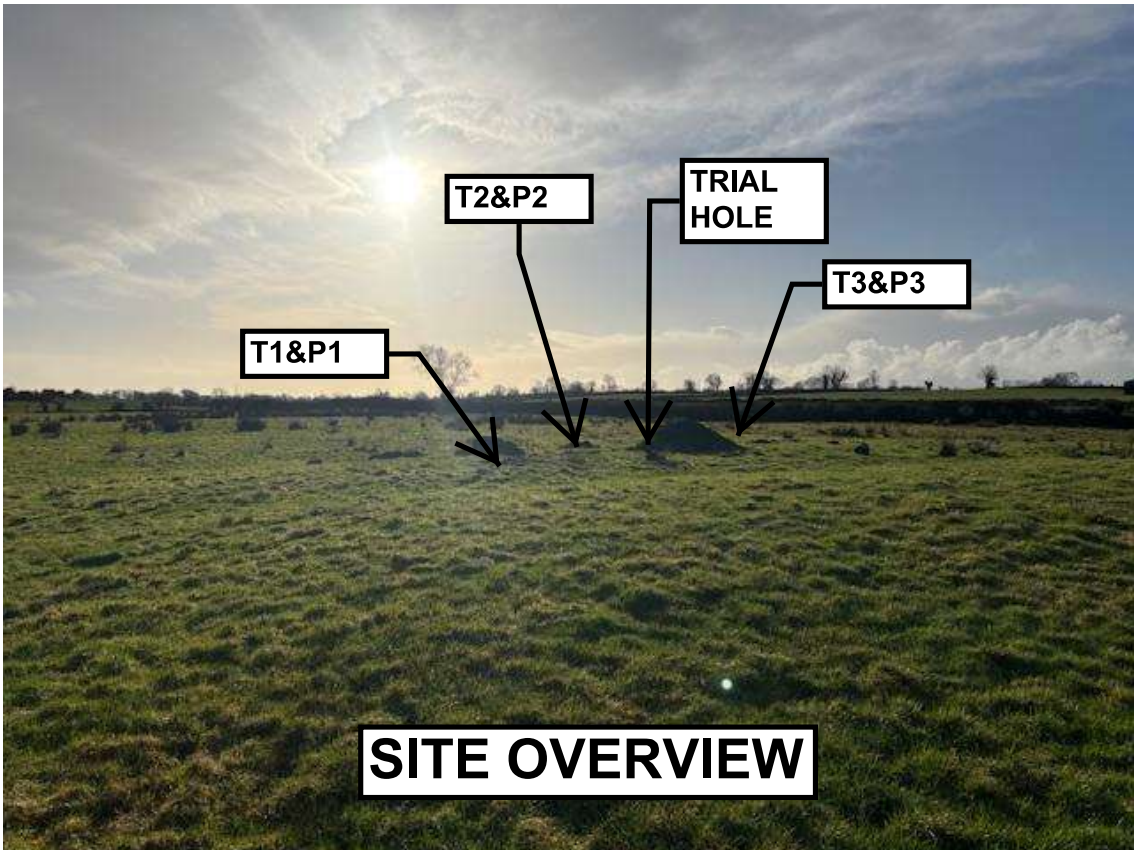
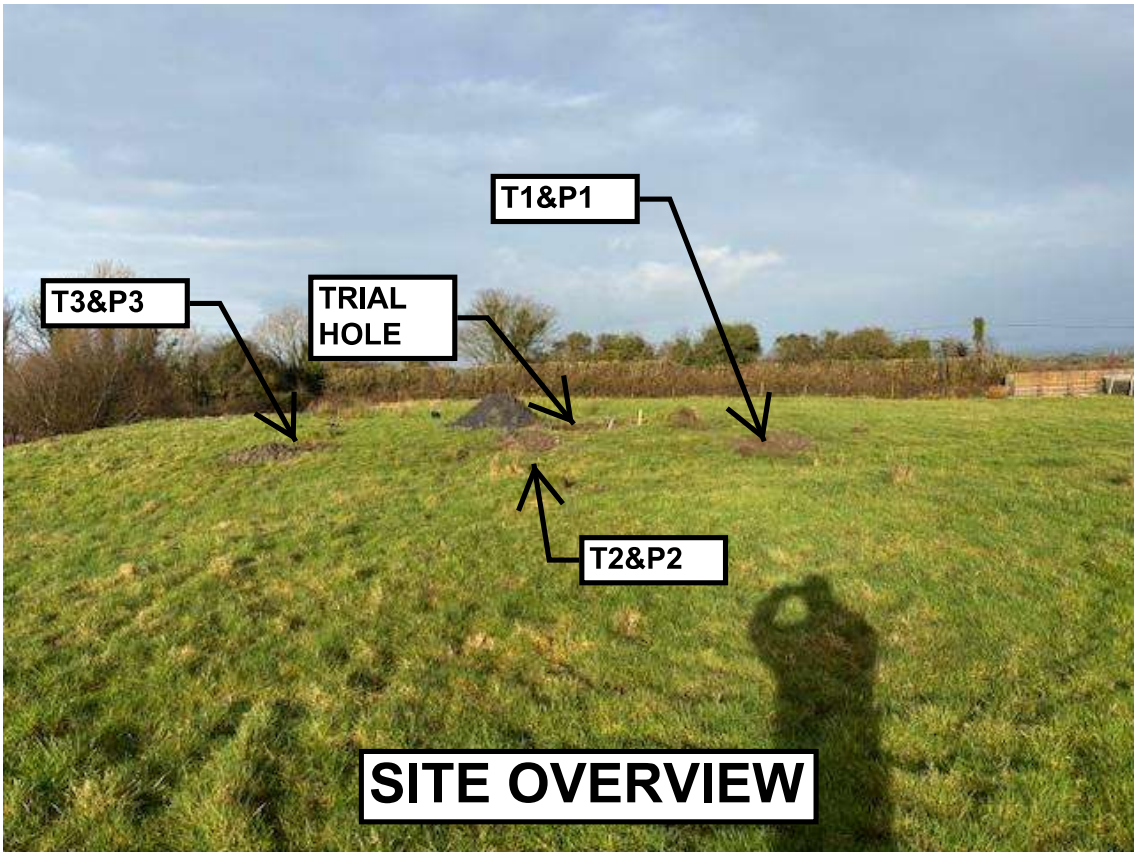





TRIAL HOLE



Graf Site Specific Wastewater Treatment Recommendation

Client: Galway County Council
Site Address: Lisdonagh, Headford, Co. Galway
Population Equivalent: 6
Sub surface Test Value: 31.01
Surface Test Value: 28.06
Proposed Solution: One 2 Clean 7PE Wastewater treatment system with external Pumped discharge followed by a Tertiary Filter over 45m ² Gravel bed .

Graf Ireland

Milltown Business Park | Milltown | Co Galway | Ireland
T: 093 51765 | F: 086 1302915 | E: www.grafireland.ie
A branch of Graf UK Ltd | Registered in Ireland No:908219



Graf Site Specific Wastewater Treatment Recommendation

System Proposal:

Based on the Information provided, we recommend for your site a Graf One 2 Clean 7pe Wastewater treatment plant which is designed to treat up to 1050 Litres of Wastewater per day. This is based on the EPA Code of Practice loading rate of 150 Litres/Person per day. **The Graf One 2 Clean is manufactured in accordance with EN12566-3 and fully complies with SR66.**

We propose to add an external pump chamber to the GRAF 7PE One2Clean system, the pump chamber will feed via 40mm rising main to the tertiary coconut filter placed on top of a 300mm deep bed of stone 45m²

We recommend that the effluent be treated in a Secondary Wastewater Treatment System and thereafter discharge to a coco filter (tertiary treatment system) with final discharge to ground. We recommend that the effluent be treated with a Tertiary Treatment System. It is proposed to gravity flow to the secondary treatment unit, pump to the tertiary unit and discharge to 300mm deep gravel distribution layer (Pea Gravel, 10-20mm) in accordance with T 10.6 of the EPA Code of Practice The bed must be laid in accordance with section 10.1 "Option 1 Direct Discharge" on a flatbed so the runoff can filtrate to ground. There must be 900mm of unsaturated subsoil under the filtration bed in accordance with Table 6.3 (Pea Gravel, 10-20mm), wrapped in terram and topsoil put back over this area.

Table 10.1: Infiltration/treatment area and trench length design for tertiary treatment, per PE

Percolation values (PVs)	Pumped or underlying gravity discharge (Options 1 and 2)	Gravity discharge into 500 mm wide trenches (Option 3)	Low-pressure pipe distribution into 300 mm wide trenches (Option 4)	Drip dispersal system (Option 5)	Tertiary Infiltration area (Option 6)
	Area required per person (m ²)	Trench length required per person (m)	Trench length required per person (m)	Area required per person (m ²)	Area required per person (m ²)
3 ≤ PV ≤ 20	≥7.5	≥6	≥6	≥5	≥3.75
21 < PV ≤ 40	≥15	≥12	≥12	≥14	≥7.5
41 < PV ≤ 50	≥30	≥17	≥17	≥16	≥15
51 < PV ≤ 75	≥50	≥19	≥19	≥22	≥25
76 < PV ≤ 90	-	-	≥28	≥34	-
91 < PV ≤ 120	-	-	-	≥54	-

Graf Ireland

Milltown Business Park | Milltown | Co Galway | Ireland
 T: 093 51765 | F: 086 1302915 | E: www.grafireland.ie
 A branch of Graf UK Ltd | Registered in Ireland No:908219



Wastewater Treatment Solutions

WASTEWATER TREATMENT SYSTEMS & SEPTIC TANKS



ADVANCED WASTEWATER TREATMENT SYSTEMS

ONE 2 CLEAN

SEPTIC TANKS

IRELAND

Welcome to Graf

By Cathal Keane, Director, Graf Ireland Environmental



World's largest injection moulding machine

For more than 50 years, the GRAF brand has represented high-quality plastic products. Our Carat wastewater tanks represent the state of the art. Our long-standing partner KLARO, which joined our group of companies in 2014, has grown over the last 10 years to become the European market leader in small SBR treatment systems with airlift technology. Our small wastewater treatment systems are already being used by more than 240,000 satisfied customers around the world. When you buy a GRAF wastewater treatment system, you benefit from the experience gained from more than 240,000 satisfied wastewater customers and the quality of two established brands in local wastewater disposal.

Quality comes first

GRAF uses state-of-the-art production facilities. This is the only way to guarantee superlative quality at attractive prices. A high standard of quality in production is an essential foundation for unique products. End-to-end quality assurance and a high level of automation guarantee maximum reliability in production. GRAF broke into new ground by using injection embossing to make the Carat wastewater tank. To manufacture this tank, GRAF commissioned the development and construction of the world's largest injection moulding machine.



Blow moulding



Rotational moulding

How to choose a wastewater treatment system

Wastewater solutions for:

e.g. domestic properties



- **one2clean one-tank system** (>> page 6)
- **Septic tank** (>> page 11)

Wastewater solutions for:

e.g. villages, office buildings, campsites, hotels

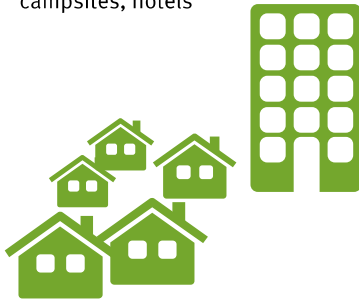

- **one2clean two-tank system** (>> page 6)
- **Advanced wastewater treatment multi-tank system** (>> page 9)

Wastewater solutions for:

e.g. holiday homes



- **Advanced wastewater treatment multi-tank system** (>> page 9)
- **Septic tank** (>> page 11)

The Benefits of injection moulding systems

Plastic – clear advantages

Because of their low weight, plastic tanks can be installed without heavy equipment. This means that they can be easily transported and installed in locations that are difficult to access. Plastic tanks, have smooth inner surfaces that will not corrode.

Sustainability starts with production

GRAF products help to protect the environment, so it goes without saying that they are also manufactured in an environmentally friendly way. Injection-moulding a plastic part usually requires up to 2.7 kilowatt

hours of electricity per kilogram of plastic. GRAF needs just 0.38 to 0.5 kilowatt hours.

The injection moulding process therefore consumes up to **85% less energy** than normal.

The heat generated during manufacturing is processed by a modern heat recovery system and is used to heat the production and logistics buildings.

Durable products: reliable investment

Right from the product development stage, GRAF attaches great importance to durable design. Our decades of experience combined with modern production techniques guarantee that our plastic tanks last for over 50 years. GRAF offers a warranty of up to 25 years for its wastewater tanks. A 3-year warranty is offered for SBR technology, with an optional 6-year extended warranty. The efficiency of our wastewater treatment systems is regularly monitored by independent institutes. All products manufactured by GRAF are also 100% recyclable.

Benefits of the Carat system

The only wastewater underground tank of it's kind!

Unique manufacturing process

The GRAF Carat underground tank is unlike any other underground tank in the world. It is the largest tank of its kind to be manufactured by injection compression moulding. This technique provides the tank with unbeatable stability and ensures that each component is produced with the highest of accuracy.

Unlike other underground tanks, the wall thickness is equal in all areas of the tank. The production tolerances are kept to a minimum, resulting in a product of the highest quality, which is strong, accurate, reliable and extremely user friendly.

To manufacture the Carat range, one of the worlds largest injection moulding systems had to be developed.

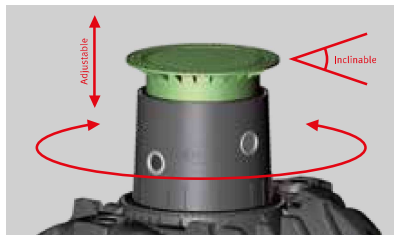

The tank that turns it head for you

The GRAF Carat underground tank has a rotating tank dome. The tank dome can be aligned with the connections independently of the tank - this makes installation much easier! All installation pipes are connected using the five standard lip seals. The Carat telescopic dome shaft connects the system to the ground surface. The height of the tank can be smoothly adjusted to suit the local conditions and it can be tilted by 5°. The whole system is flush with ground level.



Flush with ground level

The Carat underground tank has numerous seals to efficiently stop dirt getting into the tank. This means that groundwater cannot get into the tank and, thus, dirt particles cannot contaminate the wastewater. The seals are in the intersection between the tank and the tank dome and between the tank dome and the telescopic dome shaft. All supply pipes connected to the tank dome are also sealed with five lip seals as standard.

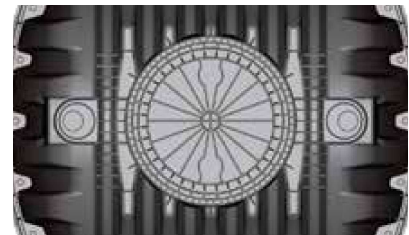

Ribbed tank base

The tank base of the Carat underground tank is extremely stable thanks to the numerous ribs. These enable the Carat to be installed in groundwater up to the middle of the tank. Furthermore, the stable base means the tank is very robust for transportation to site. The tank base has already proven its excellent rigidity in numerous computer simulations during the development process. Please follow our installation instructions for this purpose (can also be downloaded at www.grafireland.ie).

Telescopic dome shaft Mini

- With PE cover
- Suitable for pedestrian loading
- Weight 9kg
- Adjustable earth covering across upper tank surface

plus 140mm - 340mm earth covering

Order no. 371010

Telescopic dome shaft Maxi

- With PE cover
- Suitable for pedestrian loading
- Weight 15kg
- Adjustable earth covering across upper tank surface

plus 140mm - 440mm earth covering

Order no. 371011

Telescopic dome shaft cast iron

- Suitable for pedestrian loading - with childproof cast iron cover up to 3,5t
- Weight 55kg
- Adjustable earth covering across upper tank surface

plus 140mm - 440mm earth covering

Order no. 371020

Tank dome Mini

Tank dome Maxi

Tank extension piece (250-1000mm)
Dimensions

Volume [l]	Width b [mm]	Length l [mm]	Height h [mm]	Height h _{tot} [mm]	Height of tank dome ht [mm]	Inner Ø of tank dome [mm]	Weight [kg]	Order no.
2,700 (700 US gal.)	1565 (61.6")	2080 (81.9")	1400 (55.1")	2010 (79.1")	610 (24.0")	650-800 (25.6-31.5")	120 (265 lbs.)	372024
3,750 (1,000 US gal.)	1755 (69.1")	2280 (89.8")	1590 (62.6")	2200 (86.6")	610 (24.0")	650-800 (25.6-31.5")	150 (331 lbs.)	372025
4,800 (1,250 US gal.)	1985 (78.2")	2280 (89.8")	1820 (71.6")	2430 (95.7")	610 (24.0")	650-800 (25.6-31.5")	185 (408 lbs.)	372026
6,500 (1,700 US gal.)	2190 (86.2")	2390 (94.1")	2100 (82.7")	2710 (106.7")	610 (24.0")	650-800 (25.6-31.5")	220 (485 lbs.)	372027

Technical data

Max. earth covering (without groundwater vehicle loading)	1200 mm (47.2")
Max. vehicle weight	Suitable for vehicle loading (3,5 t) Higher loads on request
Earth covering required for vehicle loading	800 - 1200 mm (31.5 - 47.2")
Groundwater stability	up to middle of tank
Earth covering required for groundwater stability	800 - 1000 mm (31.5 - 39.4")
Connection	DN 100 / DN 150 / DN 200 on top

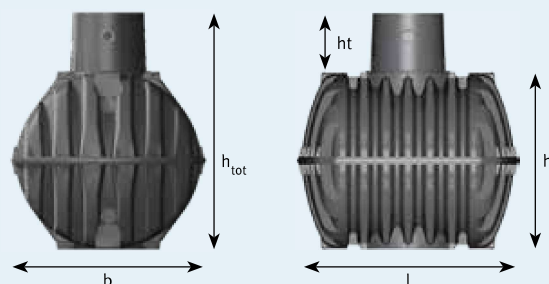

The one2clean system

The only wastewater underground tank of it's kind!

- ✓ Only one tank with just one chamber required
- ✓ Less energy consumption and less wear
- ✓ No mechanical elements in the wastewater
- ✓ No pumps in the wastewater
- ✓ No electrical components in the wastewater
- ✓ Incredibly low volume of sewage sludge



one2clean set-up kit

- Conventional wastewater treatment systems require up to three pumping processes. one2clean only requires one pumping process, which saves energy and extends the lifetime of the air compressor – the core part of the system
- Rugged clear water lifter manufactured in one seamless piece. No connectors or screws necessary
- Simple maintenance via an integrated, self-cleaning sampling container

one2clean system control

- The one2clean has a compact controller
- The microprocessor control system ensures simple operation and maintenance

Wastewater tank

- Telescopic cover
- State-of-the-art manufacturing for maximum stability
- Suitable for vehicle loading in conjunction with telescopic vehicle dome shaft
- 100% watertight and corrosion-resistant
- Can be installed in groundwater

Technical data

System	one2clean
System conformity	EN 12566-3
Purifying technology	fully biological SBR lifting technology
One-tank systems available up to	9 inhabitants 1,350 l/d
Two-tank systems available up to	18 inhabitants 2,700 l/d
Maintenance interval	1 – 2 per year
Warranty for underground tank	10 years
Warranty for purifying technology	3 years
Cleaning performance	7, 14, 0.5
Control	
Holiday mode	Manual
+D Removal of nitrogen	●
+C Carbon infeed	○
Logbook function	●
Operation	4 keys
External control cabinet for installing control unit outdoors	○
Annual power consumption	230 kWh (5 inhabitants 750 l/d)

Parameter	%	mg/l
COD (chemical oxygen demand)	94.2%	43
BOD ₅ (biochemical oxygen demand)	98.0%	7
SS (suspended solids)	96.3%	14
NH ₄ -N	98.3%	0.5
N _{total}	87.0%	7.9

Results of practical testing undertaken by the Prüfinstitut für Abwassertechnik (Testing Institute for Wastewater Technology), Aachen

- Standard equipment
- Available as options
- not available

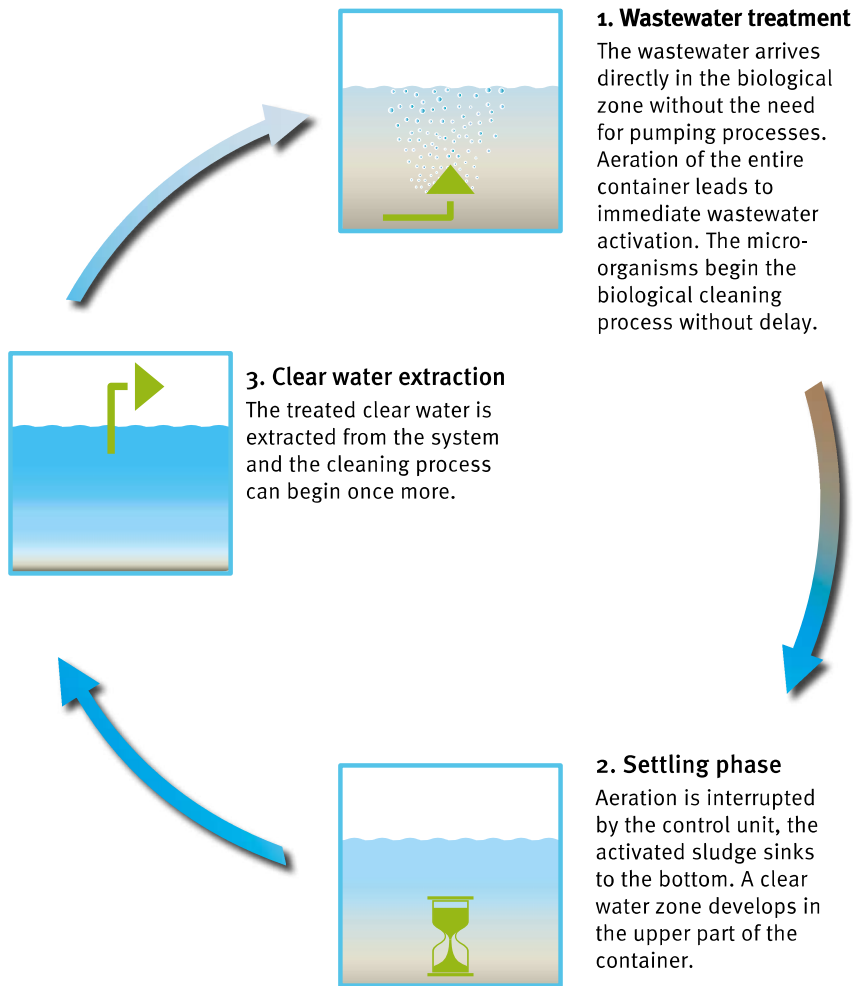

Incredibly low volume of sewage sludge

- Aeration of the entire wastewater tank
- Immediate wastewater activation
- Minimisation of the sludge
- Less sludge removal
- Cost savings

Conventional wastewater treatment systems



one2clean



Minimum maintenance costs

- Simple construction
- High-quality components
- As much technology as necessary, as little technology as possible.
- Integrated sampling point

Minimum power consumption

- one2clean has only one pumping process, reducing energy consumption and running costs
- Economical motor valve
- Energy-optimised membrane compressor

one2clean only needs 3 steps to produce clear water

The wastewater treatment is carried out in one chamber in just one tank. This eliminates unnecessary pumping processes and sludge return.

one2clean is odourless

The entire volume of wastewater is immediately activated with oxygen using the unique one2clean technology. The final process of the one2clean produces an odourless, clear treated water for extraction to soakaway or waterway.

one2clean already meets the needs of tomorrow

one2clean achieves sustainable discharge values with an efficiency factor of up to 99%! This offers high investment security – even if legal requirements become stricter.

One-tank system

Inhabitants [max.]	Max. daily flow [l/d]	Max. organic load [kg BOD ₅ /d]	Total volume [l]	Volume [l]	Length [mm]	Width [mm]	Height [mm]	Weight [kg]
5	750	0.3	3,750	3,750	2280	1755	1880	150
7	1,050	0.42	4,800	4,800	2280	1985	2110	185
9	1,350	0.54	6,500	6,500	2390	2190	2390	220

Two-tank system

Inhabitants [max.]	Max. daily flow [l/d]	Max. organic load [kg BOD ₅ /d]	Total volume [l]	Volume [l]	Length [mm]	Width [mm]	Height [mm]	Weight [kg]
10	1,500	0.6	7,500	2 x 3,750	5160	1755	1880	300
14	2,100	0.84	9,600	2 x 4,800	5160	1985	2110	370
18	2,700	1.08	13,000	2 x 6,500	5380	2190	2390	440

one2clean accessories

GRAF EPP control cabinet - Easy, flexible application

- Easy access for maintenance
- Function checking is simple as the control unit is located immediately next to the system
- Ideal solution for large distances from the house (>20m)
- Flexible use of the proven GRAF EPP control cabinet in a plastic external column
- Lockable housing in sturdy, weather-resistant plastic
- Integrated double power socket for easy maintenance

Pumped outlet

- Integrated pumped outlet option
- Overflow guard with audible alarm
- Plug and play operation
- Compatible with all percolation types



GRAF Plastics external control cabinet S for EP control cabinet (size upto 7 inhabitants)

GRAF Plastics external control cabinet M for EP control cabinet (size upto 18 inhabitants)

Empty pipe seal DN 100

- Air-tight seal for empty pipe
- No insulating foam required
- Clean, professional solution



Minimum power consumption

- one2clean has only one pumping process, reducing energy consumption and running costs
- Economical motor valve
- Energy-optimised membrane compressor



Only 46 kWh per person and per year!

- ✓ No live electrical parts in the water
- ✓ Low power consumption
- ✓ Optional automatic adjustment to living situation (underload detection)
- ✓ Optional remote monitoring
- ✓ High-quality components mean low maintenance costs



Super-quiet control cabinet

- Extremely low noise thanks to EPP housing and very quiet air compressor
- Battery-free power failure detection
- Very easy installation
- Interchangeable plug-in components



High-tech installation kit

- Integrated self-cleaning sampling container
- Each lifter manufactured as a single piece. No connectors or screws necessary
- Colour-coded and pre-assembled
- Special lifter design prevents sludge from leaking in
- Lifters easy to remove for maintenance without the use of tools

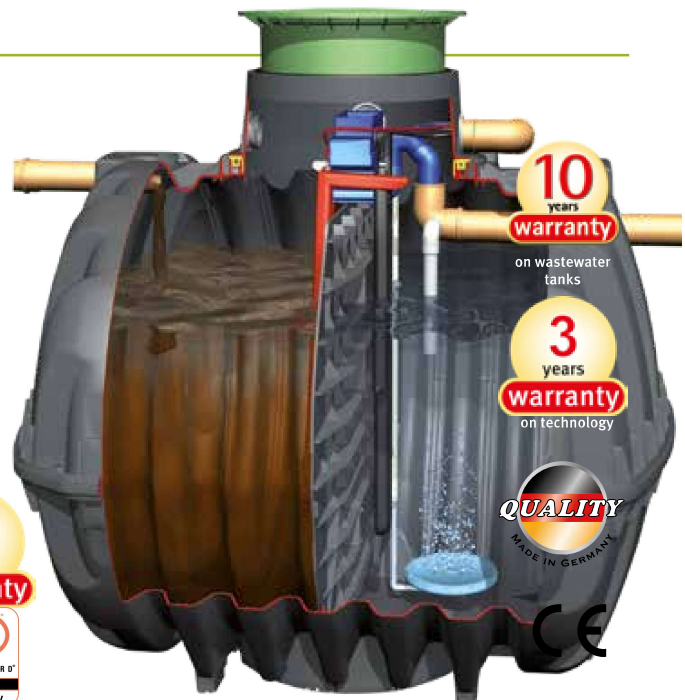

Wastewater tank

- Telescopic cover
- State-of-the-art manufacturing for maximum stability
- Suitable for vehicle loading in conjunction with telescopic vehicle dome shaft
- 100% watertight and corrosion-resistant
- Can be installed in groundwater

Advanced wastewater treatment systems

Technical data

System	Klaro Easy
System conformity	EN 12566-3
Purifying technology	fully biological SBR lifting technology
One-tank systems available up to	9 inhabitants 1,350 l/d
Maintenance interval	1 – 2 per year
Warranty for underground tank	10 years
Warranty for purifying technology	3 years
Cleaning performance	7, 14, 0.5 / 12, 20, 12
Control	KL24plus (+K)
Holiday / economy mode (underload detection)	Automatic
Back pressure monitoring	●
+R Remote transmission (GSM modem)	○
+P Phosphate removal	○
+C Carbon infeed	○
+H Hygiene package (Disinfection)	○
+D Removal of nitrogen	○
Control power failure recognition	●
Temperature sensor to protect against overheating	●
Logbook function	●
Operation	14 keys
Serial interface for software updates	●
External control cabinet for installing control unit outdoors	○

Parameter	%	mg/l
COD (chemical oxygen demand)	94.2 / 91.9%	43 / 51
BOD ₅ (biochemical oxygen demand)	98.0 / 95.9%	7 / 12
SS (suspended solids)	96.3 / 94.4%	14 / 20
NH ₄ -N	98.3 / 65.4%	0.5 / 12
N _{total}	87.0 / 57.1%	7.9

Results of practical testing undertaken by the Prüfinstitut für Abwassertechnik (Testing Institute for Wastewater Technology), Aachen

- Standard equipment
- Available as options
- not available

Advanced wastewater treatment systems

Special requirements

Systems for more than 50 inhabitants work on the same principle as small wastewater treatment systems and use the SBR process. Because of the special requirements involved, all systems for more than 50 inhabitants are planned as individual projects. Our experienced team of engineers and technicians will help you to plan your project. We take all local circumstances into account from the concept planning phase to implementation.



Options



The proven options of the advanced wastewater treatment systems are also available on request for large systems.



Inhab. [max.]	Max. daily flow [l/d]	Max. organic load [kg BOD ₅ /d]	Volume [litres]	Length [mm]	Width [mm]	Product code
25	3,750	1.50	4x 4,800	10620	1985	372708
35	5,250	2.10	4x 6,500	12360	2390	372709
50	7,500	3.00	6x 6,500	12360	7950	372710
75	12,250	3.60	2x 16,000	9900	2500	G50036
90	13,500	5.40	2x 22,000	12900	2500	G50038
100	15,000	7.20	2x 22,000	12900	2500	G50040
150	22,500	9.00	2x 32,000	17700	2500	G50042
200	30,000	10.80	4x 22,000	26400	2500	G50044
250	45,000	15.00	1x 52,000 2x 32,000	13300	8700	G50046
300	45,000	18.00	1x 52,000 2x 32,000	13300	8700	G50048
350	52,500	21.00	3x 26,000 2x 38,000	19900	5600	G50050
400	60,000	24.00	3x 22,000 2x 44,000	21400	5600	G50052
450/500	75,000	27.00/30.00	3x 22,000 4x 32,000	27500	5600	G50054
550/600	90,000	33.00/36.00	3x 26,000 4x 32,000	16200	11800	G50056
650/700	105,000	39.00/42.00	2x 32,000 4x 38,000	27500	5600	G50058
750/800	120,000	45.00/48.00	1x 38,000 3x 22,000 6x 28,000	26200	8700	G50060
850/900	135,000	51.00/54.00	1x 54,000 3x 22,000 6x 34,000	29100	8700	G50062
950/1000	142,500	57.00/60.00	1x 54,000 3x 22,000 6x 38,000	30500	8700	G50064

External control cabinets



L metal external cabinet



XL metal external cabinet



Concrete external cabinet

To plan your system, we need the following information:

- What type of project? (Domestic, hotel, commercial etc.)
- How many people will use the system and what is the water consumption per head?
- What legal requirements apply to wastewater at the location?
- Local power grid

Carat Septic Tank

Two chambers



Floating and removable material is extracted from domestic wastewater in mechanical wastewater tanks. This is purely mechanical cleaning.

Benefits

- Low weight: can also be installed in difficult local conditions without a crane
- Low maintenance: maintenance or cleaning work can be performed through the shafts
- Tanks can be used as rainwater harvesting systems after thorough cleaning

12566-1*
Hydraulic efficiency 99.9%

*Refer to the installation instructions for CE-compliant Septic tanks



Carat S Septic tank

Inhabitants [max]	Total volume [l]	Capacity [l]	Length [mm]	Width [mm]	Height [mm]	Weight [kg]
9	3,750	3,750	2280	1755	2200	175
15	4,800	4,800	2280	1985	2430	220
27	6,500	6,500	2390	2190	2710	260

One complete system consists of: Carat S underground tank with baffle. Also available without baffle as a one-chamber wastewater tank.

Low pressure network pipe kits

Graf Ireland offer complete pipe kits for pump discharge pressurised pipe networks, also known as pumped distribution systems. The low pressure networks work by distributing the pumped discharge from a sewage treatment plant or a septic tank through a series of small diameter pipes that

are pre drilled with small holes to allow the water to drain from the pipes, as per the EPA code of practice. The low pressure network is placed on a 300mm stone bed covered with geotextile over suitable soil sub layers. A minimum of 300mm of topsoil is then placed on top of the geotextile. Low pressure

networks are needed due to difficult site conditions for example, high water table, insufficient subsoil depth and poor soil percolation. Graf offer the full kit including rising main, non-return valves, distribution pipes, flush valves and geotextile and full installation can be provided by Graf's specialist team.





Warranty clause:

The warranty mentioned in this brochure only refers to the tank in question and not to the accessories. Within the warranty period we grant free replacement of the material. Further benefits are excluded. Pre-condition for warranty benefits are proper handling, assembly and installation according to the mounting guidelines.

N.B. Protect tanks from frost when installed above ground! In case of groundwater installation, please contact us for further information prior to purchase!

For all indications of measurements in this brochure we reserve a tolerance of +/- 3%. The usage volume of the tanks may be up to 10% lower than the tank Volume, depending on the connecting option.

Technical modifications and further development of the various products are subject to change. Errors excepted.

RAINWATER HARVESTING



INFILTRATION



WASTEWATER TREATMENT SOLUTIONS



MULTIPURPOSE CONTAINERS



Graf Ireland Environmental Ltd
Milltown Business Park
Milltown
Co. Galway
H54 RD78

T: 093 51765
E: info@grafireland.ie
www.grafireland.ie

Your expert specialist dealer:

TREATMENT PERFORMANCE RESULTS

Otto Graf GmbH
Carl-Zeiss-Str. 2-6, 79331 Teningen

EN 12566-3
Results corresponding to EN 12566-3 and S.R. 66
PIA-SR66-1605-1061

one2clean
SBR plant in one two-zone polypropylene tank

Nominal organic daily load	0.27 kg/d		
Nominal hydraulic daily load	0.75 m ³ /d		
Material	Polypropylene		
Watertightness	Pass		
Structural behaviour (Pit Test)	Pass (also wet conditions)		
Durability	Pass		
Treatment efficiency (nominal sequences)		Efficiency	Effluent
		COD	94.2 % 43 mg/l
		BOD ₅	98.0 % 7 mg/l
		NH ₄ -N	98.3 % 0.5 mg/l
		SS	96.3 % 14 mg/l
Number of desludging	Not more than once		
Electrical consumption	0.63 kWh/d		

Performance tested by:

PIA – Prüfinstitut für Abwassertechnik GmbH
(PIA GmbH)
Hergenrather Weg 30
52074 Aachen, Germany

This document replaces neither the declaration
of performance nor the CE marking.



Notified Body
No.: 1739



Certified according to
ISO 9001:2008



Prüfinstitut für Abwassertechnik GmbH
Elmar Lancé
geprüft - tested - teste

Elmar Lancé

July 2016



One2clean range and its referring test reports:

Population Equation (PE)	Drawing of model of the range	Watertightness (EN 12566-3 Annex A)	Treatment Efficiency (EN 12566-3 Annex B)	Structural Behaviour (EN 12566-3 Annex C)	Durability
Initial type test (ITT) 5		Pass PIA2008-WD-AT0805-1027b	Pass PIA2014-216B14.01	Pass For wet ground conditions also, Installation depth 1.65 m from inlet invert	Pass SKZ 114836/15
3		Pass PIA2008-WD-AT0805-1027b	Pass Range conformity according to S.R. 66:2015	Pass For wet ground conditions also, Installation depth 1.65 m from inlet invert	Pass SKZ 114836/15
7		Pass PIA2008-WD-AT0805-1027b	Pass Range conformity according to S.R. 66:2015	Pass For wet ground conditions also, Installation depth 1.65 m from inlet invert	Pass SKZ 114836/15

Population Equation (PE)	Drawing of model of the range	Watertightness (EN 12566-3 Annex A)	Treatment Efficiency (EN 12566-3 Annex B)	Structural Behaviour (EN 12566-3 Annex C)	Durability
7		<p>Pass</p> <p>PIA2008-WD-AT0805-1027b</p>	<p>Pass</p> <p>Range conformity according to S.R. 66:2015</p>	<p>Pass</p> <p>For wet ground conditions also, Installation depth 1.65 m from inlet invert</p>	<p>Pass</p> <p>SKZ 114836/15</p>
9		<p>Pass</p> <p>PIA2008-WD-AT0805-1027b</p>	<p>Pass</p> <p>Range conformity according to S.R. 66:2015</p>	<p>Pass</p> <p>PIA2016-ST-PIT-1509-1050.01</p> <p>For wet ground conditions also, Installation depth 1.65 m from inlet invert</p>	<p>Pass</p> <p>SKZ 114836/15</p>
10		<p>Pass</p> <p>PIA2008-WD-AT0805-1027b</p>	<p>Pass</p> <p>Range conformity according to S.R. 66:2015</p>	<p>Pass</p> <p>For wet ground conditions also, Installation depth 1.65 m from inlet invert</p>	<p>Pass</p> <p>SKZ 114836/15</p>



	D Kleinkläranlage one2clean 3 EW Carat S 2700 L	Artikel-Nr. article no.
	GB WWTP one2clean 3 EW Carat S 2700 L	ES

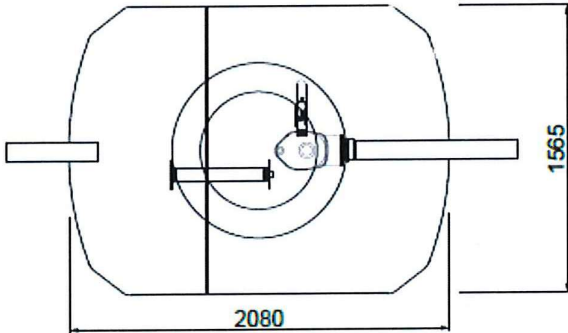

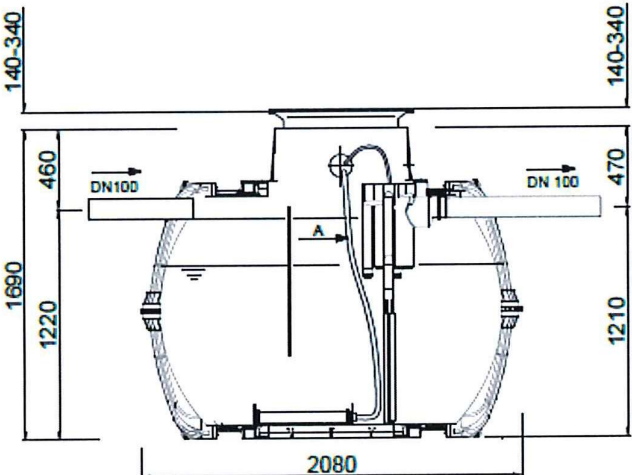

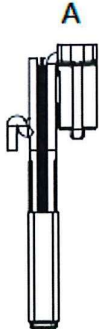

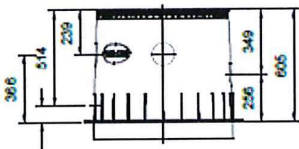

Maxi Dom (optional)

- 330 mm höhere Einbautiefe
- 330 mm more excavation depth

Otto Graf GmbH Carl-Zeiss-Str. 2-6 DE-79331 Teningen Germany info@graf-.info www.graf.info	Zeichnungsinformation drawing information	Artikelinformation article information	Alle Maßangaben in mm all dimensions in mm	
	gezeichnet drawn	CSC		Gewicht weight
	Datum date	10.01.2014		
	Toleranz tolerance	+/- 3 %		

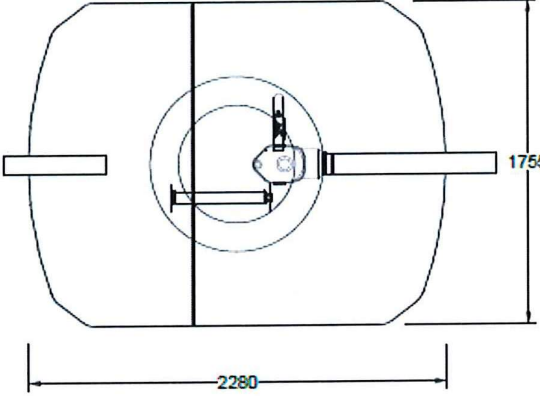
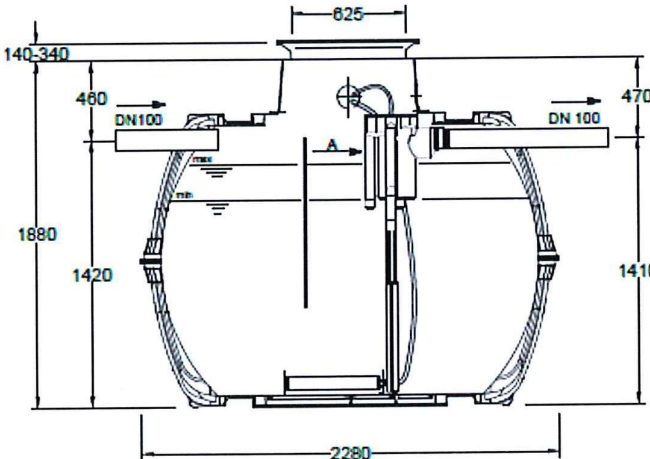
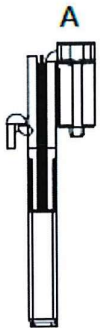
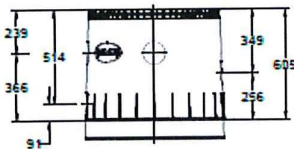

	D Kleinkläranlage one2clean 5 EW Carat S 3750 L		Artikel-Nr. article no.
	GR WWTP one2clean 5 inhab. Carat S 3750 L	ES	FR
			
			
			
			
<p style="text-align: center;">Maxi Dom (optional)</p> <ul style="list-style-type: none"> • 330 mm höhere Einbautiefe • 330 mm more excavation depth 			
Otto Graf GmbH Carl-Zeiss-Str. 2-6 DE-79331 Teningen Germany info@graf.info www.graf.info	Zeichnungsinformation drawing information		Artikelinformation article information
	gezeichnet drawn		Gewicht weight
	Datum date 13.01.2014		
	Toleranz tolerance +/- 3 %		
			Alle Maßangaben in mm all dimensions in mm

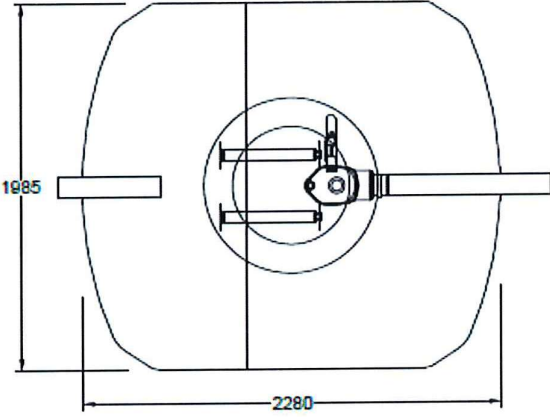
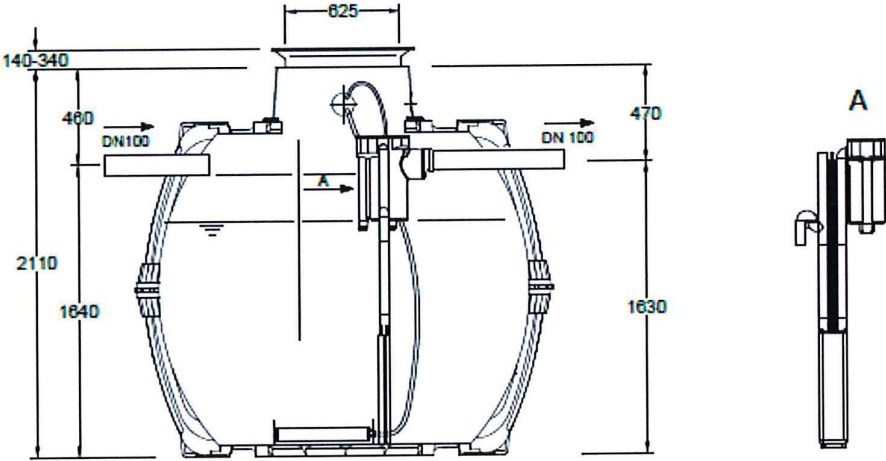
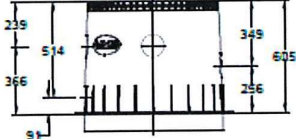

	D Kleinkläranlage one2clean 7 EW Carat S 4800 L		Artikel-Nr. article no.
	GB WWTP one2clean 7 inhab. Carat S 4800 L	ES	FR
			
			
		Maxi Dom (optional) <ul style="list-style-type: none"> • 330 mm höhere Einbautiefe • 330 mm more excavation depth 	
Otto Graf GmbH Carl-Zeiss-Str. 2-6 DE-79331 Tettingen Germany info@graf.info www.graf.info	Zeichnungsinformation drawing information		Artikelinformation article information
	gezeichnet drawn CSC		Gewicht weight
	Datum date 13.01.2014		
	Toleranz tolerance +/- 3 %		
			Alle Maßangaben in mm all dimensions in mm

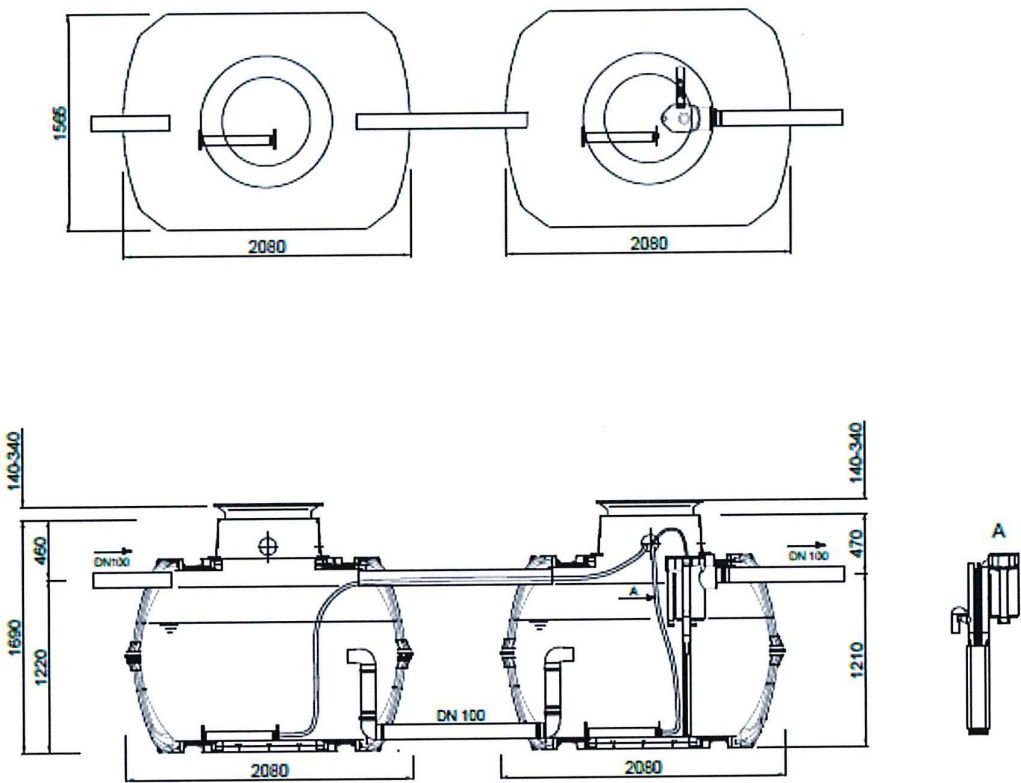

	D Kleinkläranlage one2clean 7 EW 2 x Carat S 2700 L		Artikel-Nr. article no.
	GB WWTP one2clean 7 EW 2 x Carat S 2700 L	ES	FR
			
Otto Graf GmbH Carl-Zeiss-Str. 2-6 DE-79331 Teningen Germany info@graf.info www.graf.info		Zeichnungsinformation drawing information	Artikelinformation article information
		gezeichnet drawn CSC	Gewicht weight
		Datum date 10.01.2014	
		Toleranz tolerance +/- 3 %	
			Alle Maßangaben in mm all dimensions in mm

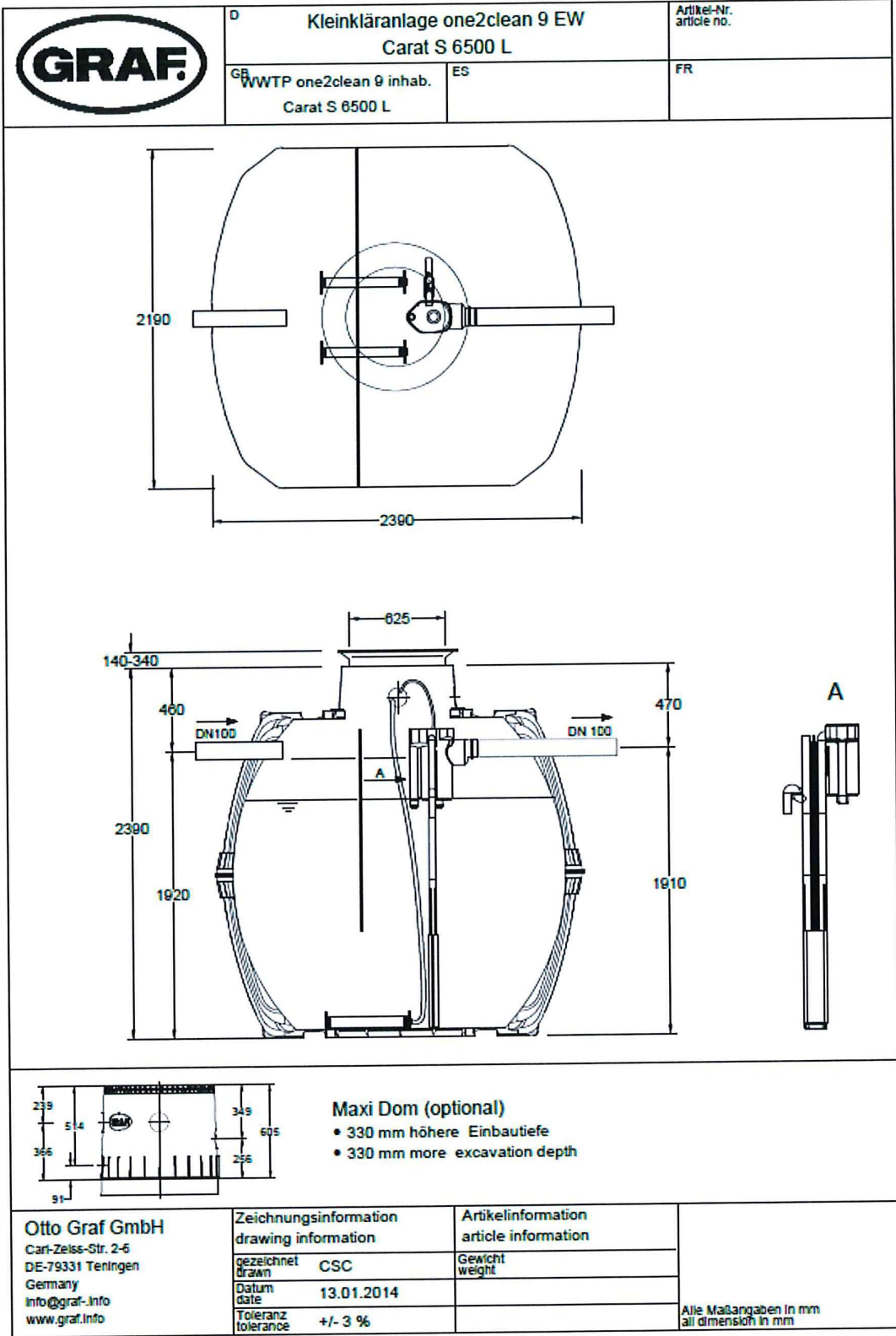



	D Kleinkläranlage one2clean 10 EW 2 x Carat S 3750 L		Artikel-Nr. article no.
	GB WWTP one2clean 10 EW 2 x Carat S 3750 L	ES	FR

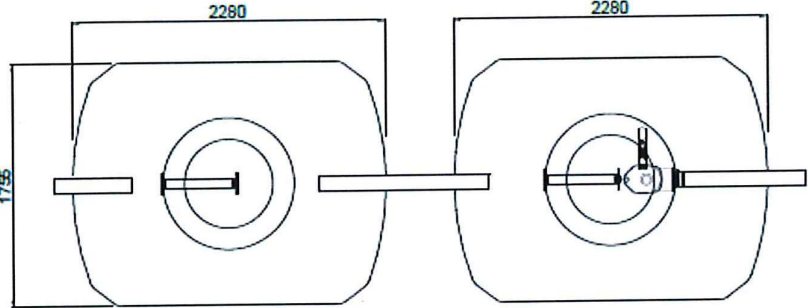

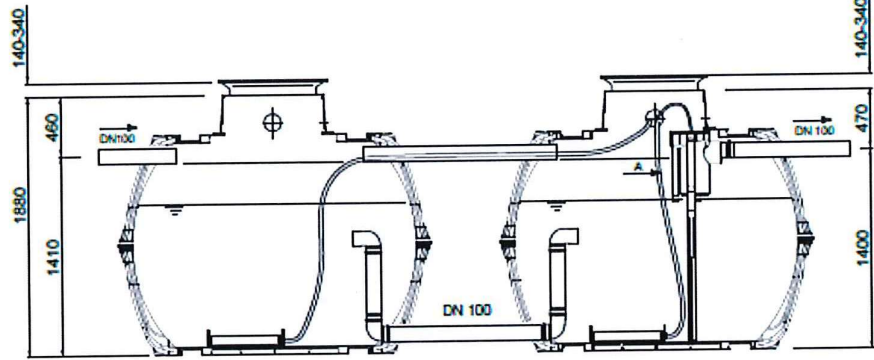

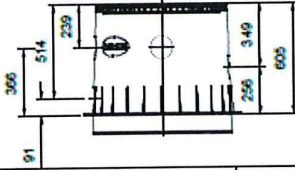

Maxi Dom (optional)

- 330 mm höhere Einbautiefe
- 330 mm more excavation depth

Otto Graf GmbH Carl-Zeiss-Str. 2-6 DE-79331 Teningen Germany info@graf-info www.graf.info	Zeichnungsinformation drawing information	Artikelinformation article information	Alle Maßangaben in mm all dimensions in mm
	gezeichnet drawn	Gewicht weight	
	Datum date		
	Toleranz tolerance		



D	Kleinkläranlage one2clean 14 EW 2 x Carat S 4800 L	Artikel-Nr. article no.
GR	WWTP one2clean 14 EW 2 x Carat S 4800 L	ES FR

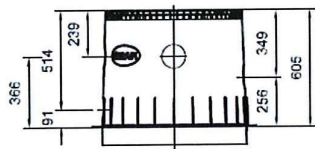
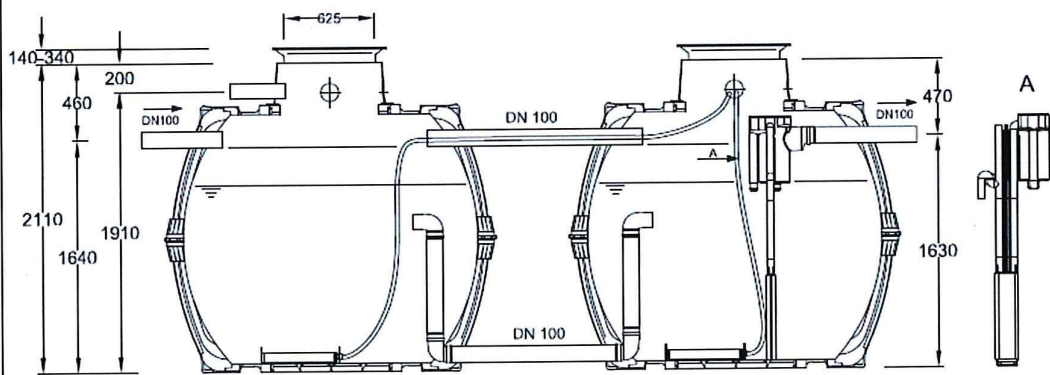
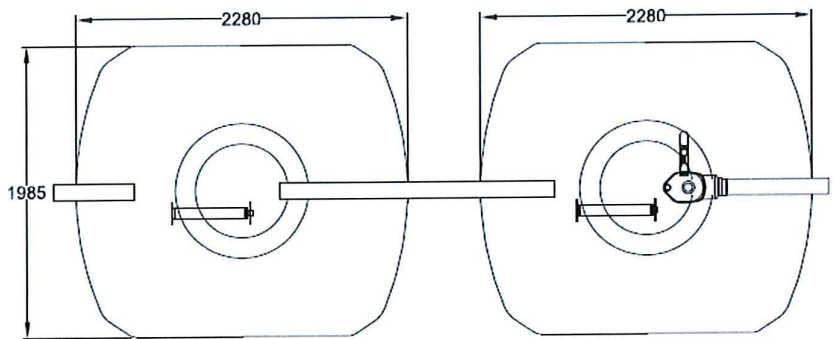

Maxi Dom (optional)

- 330 mm höhere Einbautiefe
- 330 mm more excavation depth

Otto Graf GmbH Carl-Zeiss-Str. 2-6 DE-79331 Teningen Germany Info@graf-Info www.graf-Info	Zeichnungsinformation drawing information	Artikelinformation article information	Alle Maßangaben in mm all dimension in mm	
	gezeichnet drawn	CSC		Gewicht weight
	Datum date	06.06.2013		
	Toleranz tolerance	+/- 3 %		

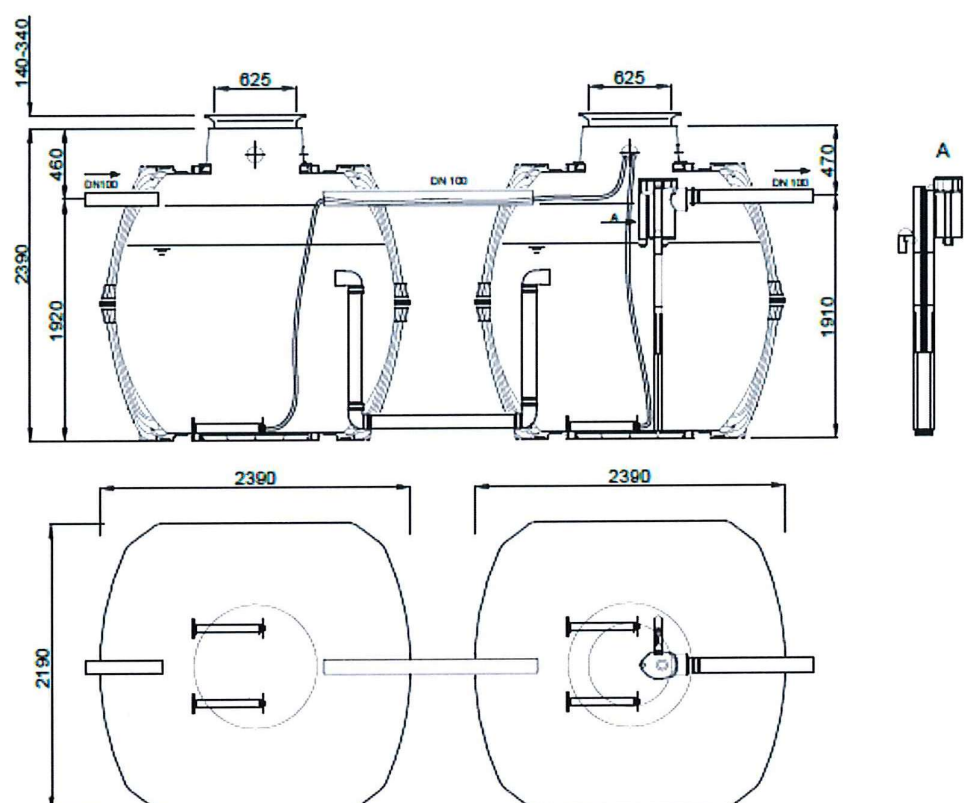
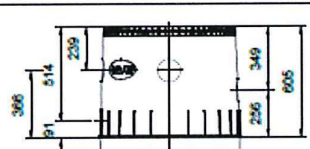

	D Kleinkläranlage one2clean 18 EW 2 x Carat S 6500 L		Artikel-Nr. article no.
	GB WWTP one2clean 18 EW 2 x Carat S 6500 L	ES	FR
			
			
<p style="text-align: center;">Maxi Dom (optional)</p> <ul style="list-style-type: none"> • 330 mm höhere Einbautiefe • 330 mm more excavation depth 			
Otto Graf GmbH Carl-Zeiss-Str. 2-6 DE-79331 Teningen Germany info@graf.info www.graf.info	Zeichnungsinformation drawing information		Artikelinformation article information
	gezeichnet drawn	CSC	Gewicht weight
	Datum date	07.06.2013	
	Toleranz tolerance	+/- 3 %	
			Alle Maßangaben in mm all dimensions in mm

CHIEFTAIN®

Coco Filter

Tertiary Treatment System
For Domestic and Commercial use

Why choose a Chieftain Coco Filter?

- **Off-the-shelf design** - a ready to install packaged tertiary treatment system
- **Easy to install** - no high skilled installation procedures required
- **Ready to go design** - just place on the infiltration/dispersal pad and connect the inlet pipe
- **Compact** - this system has a reduced footprint compared to a sand polishing filter
- Available in **8PE and 15 PE** modules
- Achievable results:



Parameters	BOD5	TSS	Ammonia
Influent mg/l	50 ± 14	40 ± 10	20 ± 2
Treated effluent mg/l	7 ± 1	3 ± 1	3 ± 2
Parameters	E. coli	Enterococci	
% Reduction	97.35%	98.22%	

Third party Testing of the Chieftain® Coco Filter for Tertiary Treatment by the National University of Ireland Galway NUIG

You should consider a Chieftain Coco Filter if:

- You are in need of a tertiary treatment filter
- You want to reduce the footprint from a soil polishing filter
- You have a small site
- Your site has a high water table or bedrock. This system could potentially eliminate the need for a raised bed.



www.molloyprecast.com
info@molloyprecast.com
057-93-26000



Certificate

Molloy Environmental Systems

Molloy Precast Products Ltd.

Coleraine, Clara Road, Tullamore, Co Offaly, Ireland

EN 12566-3

Small wastewater treatment systems for up to 50 PT

Small wastewater treatment system CHIEFTAIN® Coco Filter

PIA2019-1909-1055

Material	Polyethylene
Watertightness (Annex A)	Pass
Structural behaviour (pit test)	Pass (dry ground conditions only)
Durability	Pass

Performance tested by:

PIA – Prüfinstitut für Abwassertechnik GmbH
Hergenrather Weg 30
52074 Aachen
Germany

This document replaces neither the declaration of performance nor the CE marking.



Daniel Verschitz

November 2019

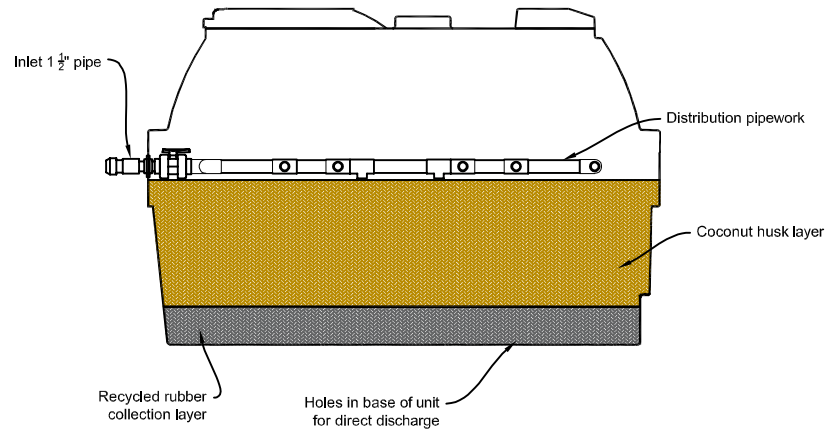
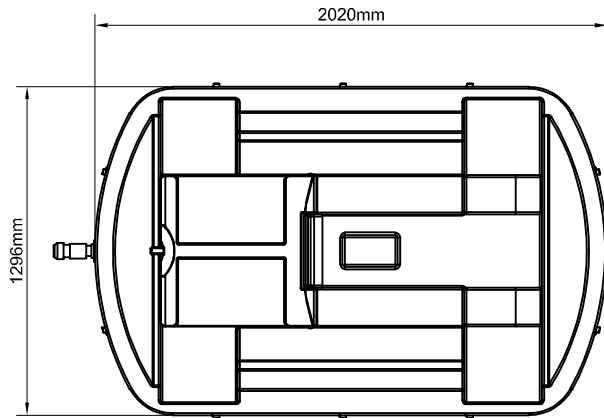
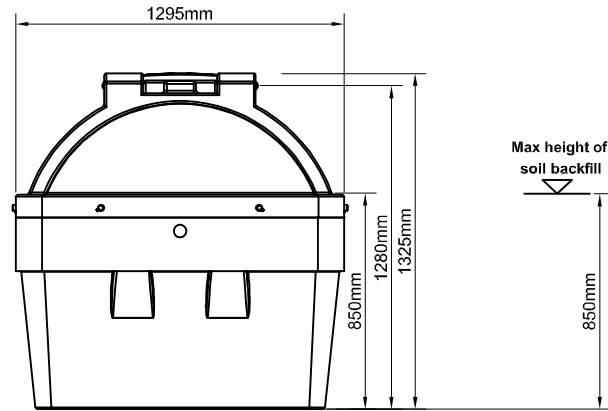
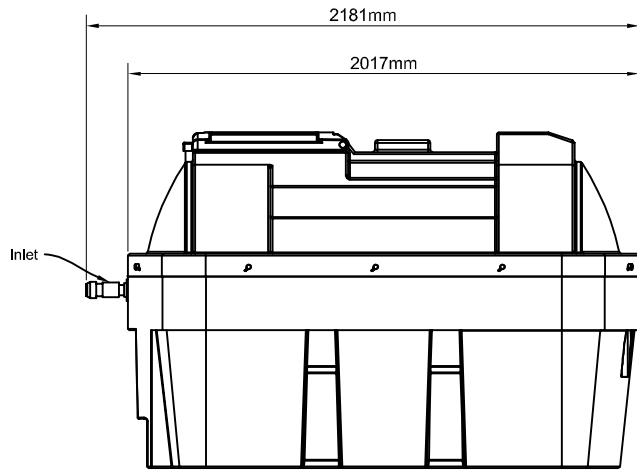

- Notes:**
- This drawing is ©. All rights reserved.
 - Do not scale from this drawing. Only for illustration purposes.
 - Specify any specific requirements prior to ordering. All civil works by customer.
 - Observe all safety regulations in regard to excavation and lifting requirements. Never leave opening uncovered or unattended at any time.
 - Must be placed on a level base.

Minimum separation details
EPA 2009 CoP Table 6.1

	Tanks	Percolation
Water Course	10m	10m
Well	10m	15-60m
Lake	50m	50m
Boundary	3m	3m
Road	4m	4m
House	7m	10m

MOLLOY
ENVIRONMENTAL SYSTEMS
Clara Rd., Tullamore, Co. Offaly
T: 057 9326000 E: info@mollyprecast.com
F: 057 9326060 W: www.mollyprecast.com







Title: 8PE Chiefain coconut filter with direct discharge
PE: 8 PE
Drg. no.: Cocco_8PE_02_040719
Date: 04/07/2019
Drawn by: SF Checked by: KR

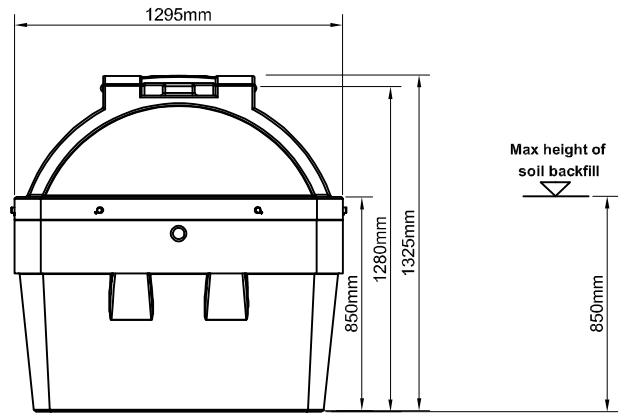
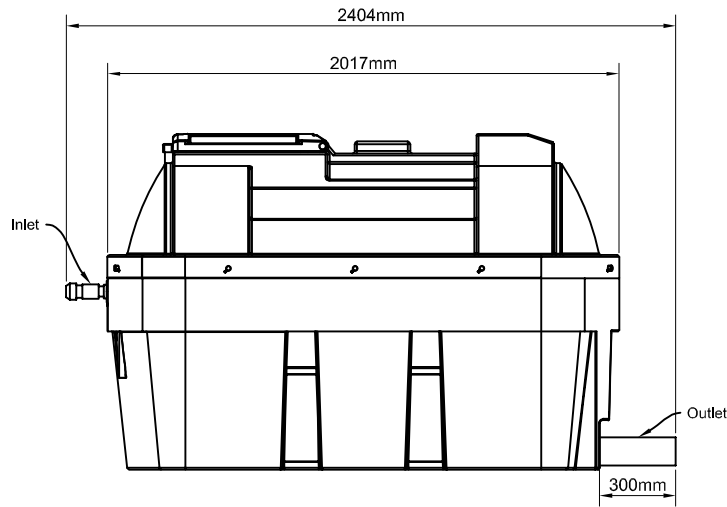

Max height of soil backfill

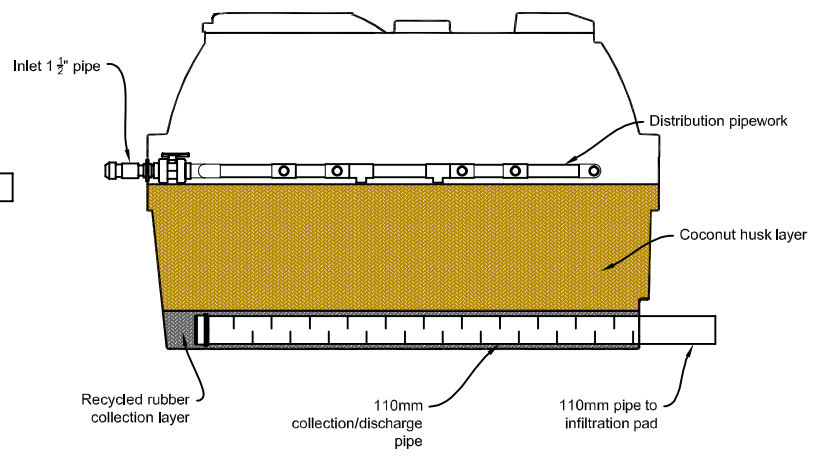
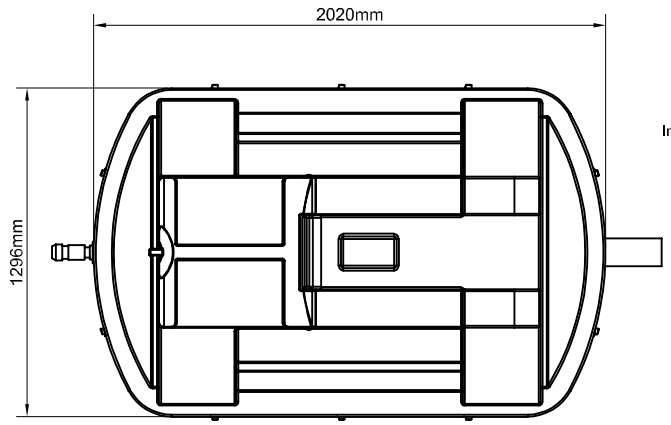

- Notes:**
- This drawing is ©. All rights reserved.
 - Do not scale from this drawing. Only for illustration purposes.
 - Specify any specific requirements prior to ordering. All civil works by customer.
 - Observe all safety regulations in regard to excavation and lifting requirements. Never leave opening uncovered or unattended at any time.
 - Must be placed on a level base.

Minimum separation details
EPA 2009 CoP Table 6.1

	Tanks	Percolation
Water Course	10m	10m
Well	10m	15-60m
Lake	50m	50m
Boundary	3m	3m
Road	4m	4m
House	7m	10m

Clara Rd., Tullamore, Co. Offaly
 T: 057 9326000 E: info@mollyprecast.com
 F: 057 9326060 W: www.mollyprecast.com

Title: 8PE Chieftain coconut filter with 110mm outlet

PE: 8 PE

Drng. no.: Coco_8PE_01_211119

Date: 21/11/2019

Drawn by: SF Checked by: KR

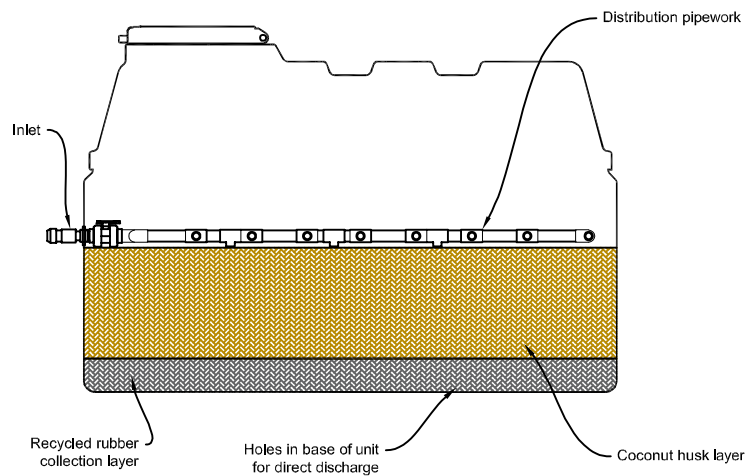
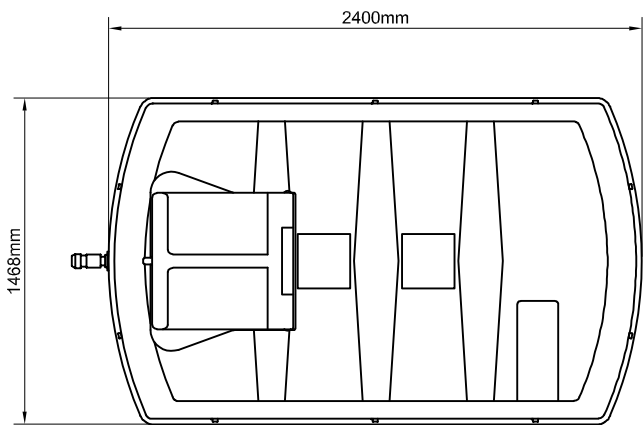
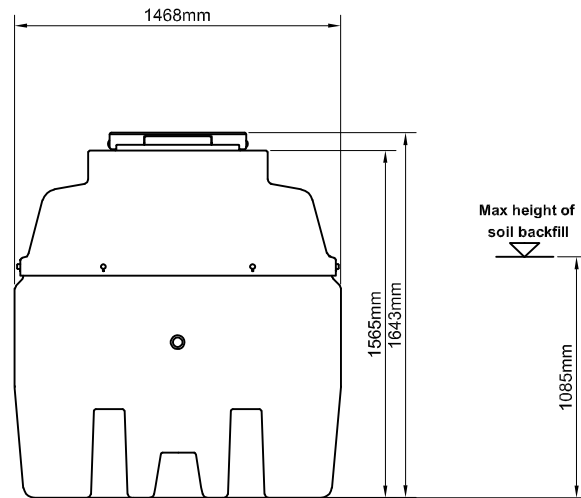
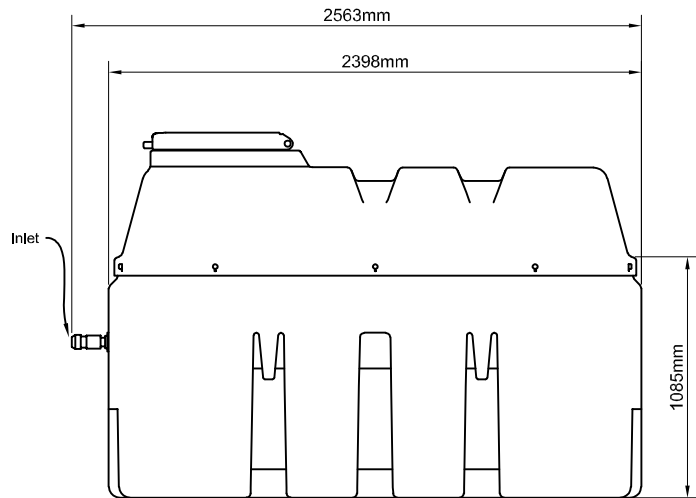

- Notes:**
- Observe all safety regulations in regard to excavation and lifting requirements. Never leave opening uncovered or unattended at any time
 - Specify any specific requirements prior to ordering. All civil works by customer
 - Observe all safety regulations in regard to excavation and lifting requirements. Never leave opening uncovered or unattended at any time.
 - The construction of all soil polishing filters should comply with the applicable soil characterisation and site suitability reports as well as the EPA CoP

Tank lifting limitations:
Max chain angle < 60°

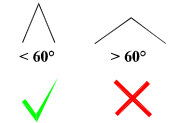

Damage caused by incorrect lifting is the responsibility of others

MOLLOY
ENVIRONMENTAL SYSTEMS

Clara Rd., Tullamore, Co. Offaly
T: 057 9326000 E: info@molloyprecast.com
F: 057 9326060 W: www.molloyprecast.com



Title: 15PE Chieftain Coconut filter with direct discharge

PE: 8PE

Drq. no.: Coco_15PE_02_211119

Date: 21/11/2019

Drawn by: SF

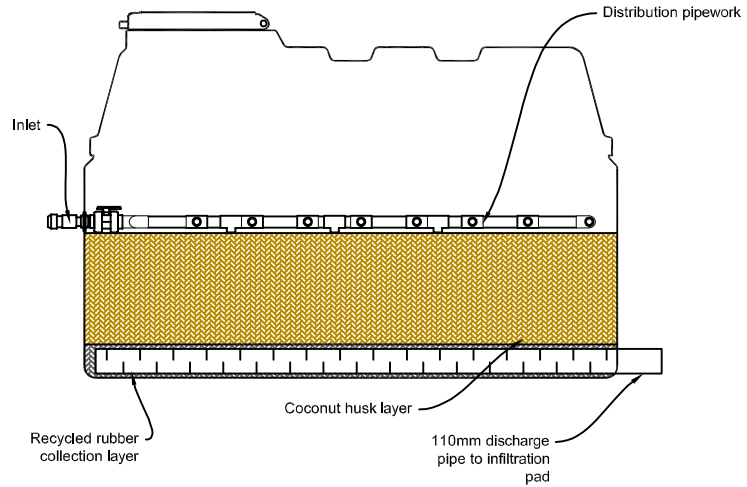
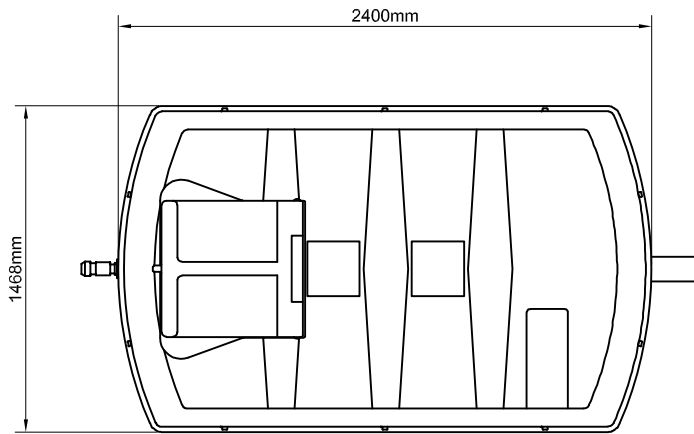
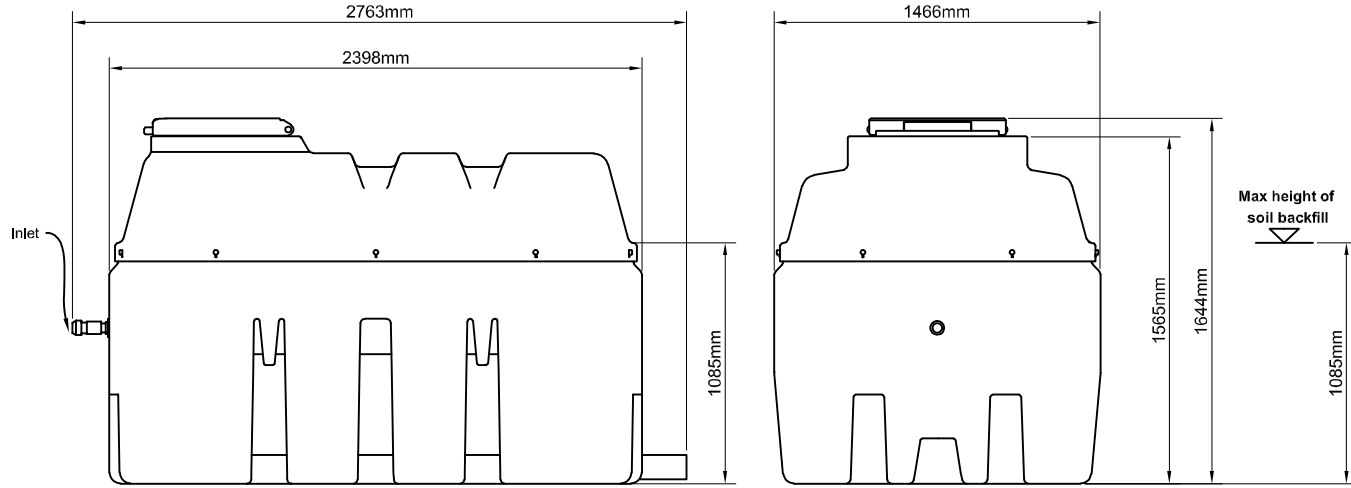

Notes:

- Observe all safety regulations in regard to excavation and lifting requirements. Never leave opening uncovered or unattended at any time
- Specify any specific requirements prior to ordering. All civil works by customer
- Observe all safety regulations in regard to excavation and lifting requirements. Never leave opening uncovered or unattended at any time.
- The construction of all soil polishing filters should comply with the applicable soil characterisation and site suitability reports as well as the EPA CoP

Tank lifting limitations:
Max chain angle < 60°

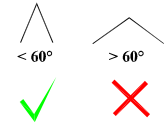

Damage caused by incorrect lifting is the responsibility of others

MOLLOY
ENVIRONMENTAL SYSTEMS

Clara Rd., Tullamore, Co. Offaly
T: 057 9326000 E: info@molloyprecast.com
F: 057 9326060 W: www.molloyprecast.com



Title: 15PE Chieftain Coconut filter with 110mm outlet

PE: 15PE

Drg. no.: Coco_15PE_01_211119

Date: 21/11/2019

Drawn by: SF

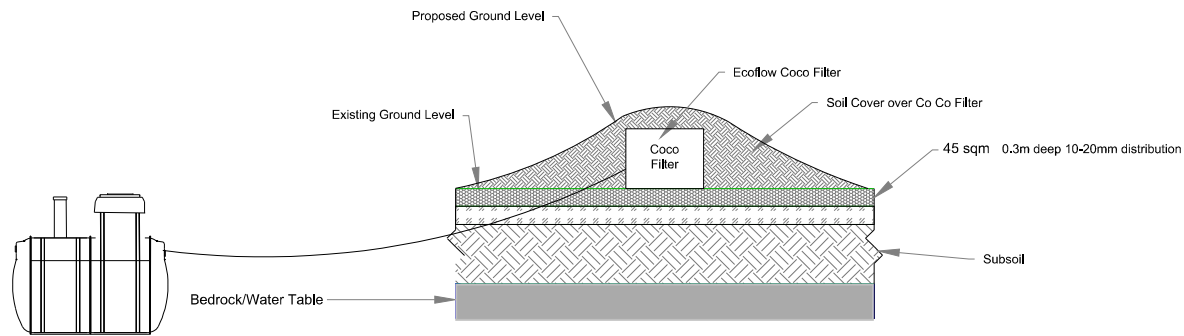

Section Through Tertiary Infiltration Area

Rev	By	Date	Description
Drawing Issue:			PLANNING
Drg. Title:			
Polishing Filter Sections			
Client:			
Galway County Council			
Project Description:			
Proposed wastewater treatment unit and raised soil polishing filter together with all ancillary site works and services at Lisdonagh, Headford, Co. Galway			
Drawings by:		Drg By:	Ckd By:
Paul Roche		P.R.	P.R.
Ardcarne,		Scale:	N.T.S
Boyle,		Date:	Feb 2026
Co. Roscommon		Drawing No:	PG 001
086 2018137		Rev:	P,01

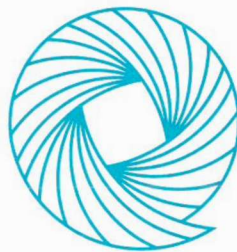

QQI AWARD

Dámhachtain Breisoideachais agus Oiliúna
Further Education and Training Award

TEASTAS CUSPÓRA SHAINIÚIL LEIBHÉAL 6
LEVEL 6 SPECIFIC PURPOSE CERTIFICATE

i
in

Oiriúnacht Suíomh Láithreáin i gcomhair Cóireáil Fuoílluisce
Site Suitability for Wastewater Treatment

le Pas
with Pass

Bronnta ar
Awarded to

Paul Roche

ar
on

14 December 2016

Príomhfheidhmeannach
Chief Executive

6S2241
F1080541
38906N

Bronnta ag Dearbhú Cáilíochta agus Cáilíochtaí Éireann faoi Chuid 4 den Acht um Cháilíochtaí agus Dearbhú Cáilíochta (Oideachas agus Oiliúint) 2012
Awarded by Quality and Qualifications Ireland under Part 4 of the Qualifications and Quality Assurance (Education and Training) Act 2012

FET Credits 10
NFQ Level 6
EQF Level 5



www.QQI.ie