

PLAN ON STRAIGHT INVERT (WITHOUT COVER SLAB)
PLAN ON CURVED INVERT (WITHOUT COVER SLAB)

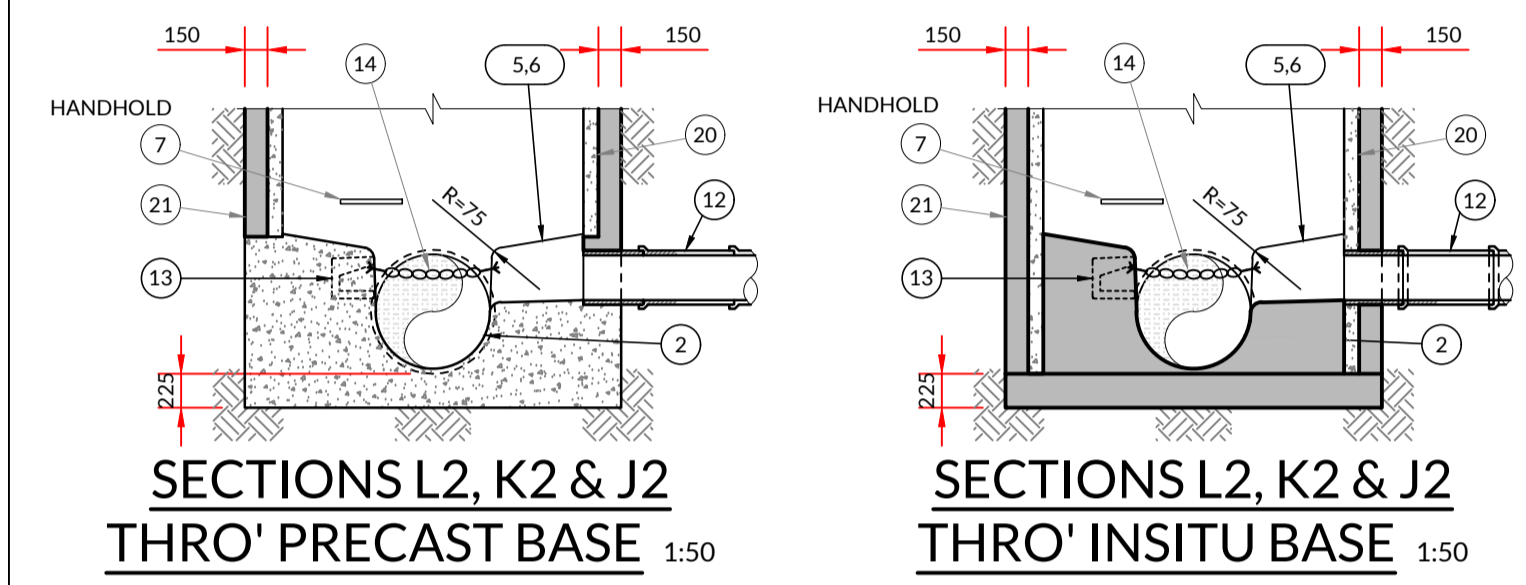

SECTIONS L2, K2 & J2 THRO' PRECAST BASE 1:50
SECTIONS L2, K2 & J2 THRO' INSITU BASE 1:50

COMMON DETAILS

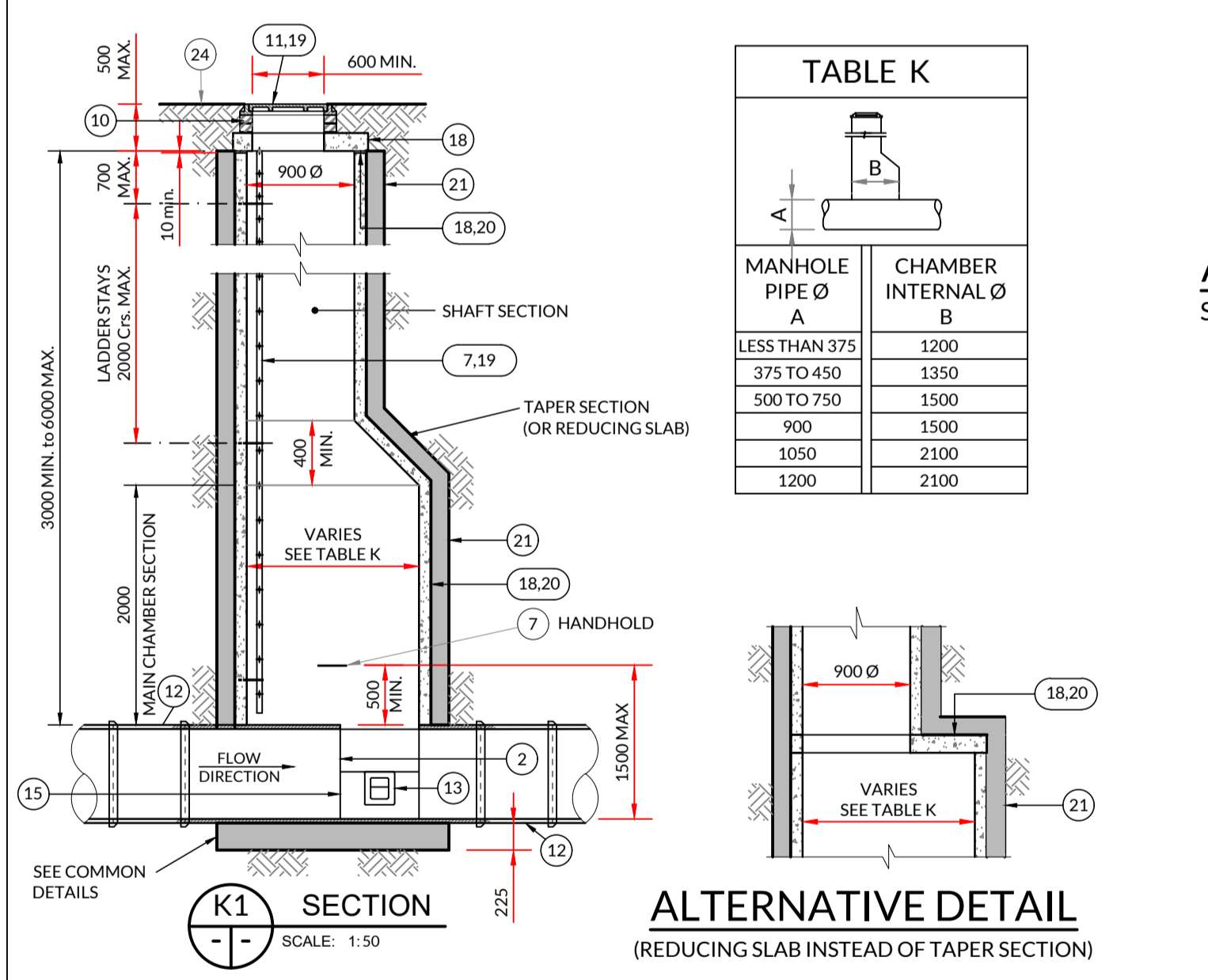

MANHOLE TYPE K
 3m ≤ DEPTH TO INVERT < 6m

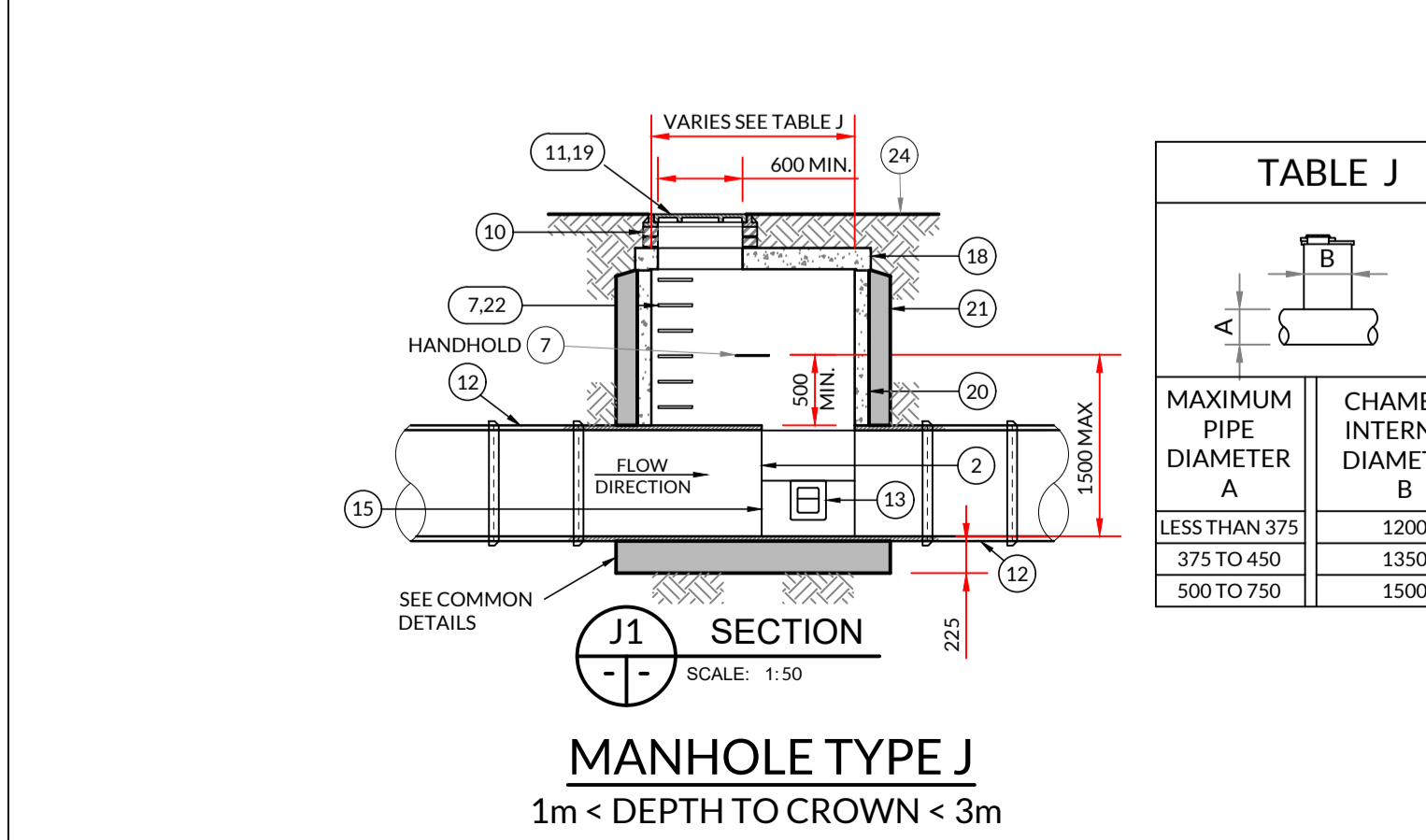

MANHOLE TYPE J
 1m < DEPTH TO CROWN < 3m

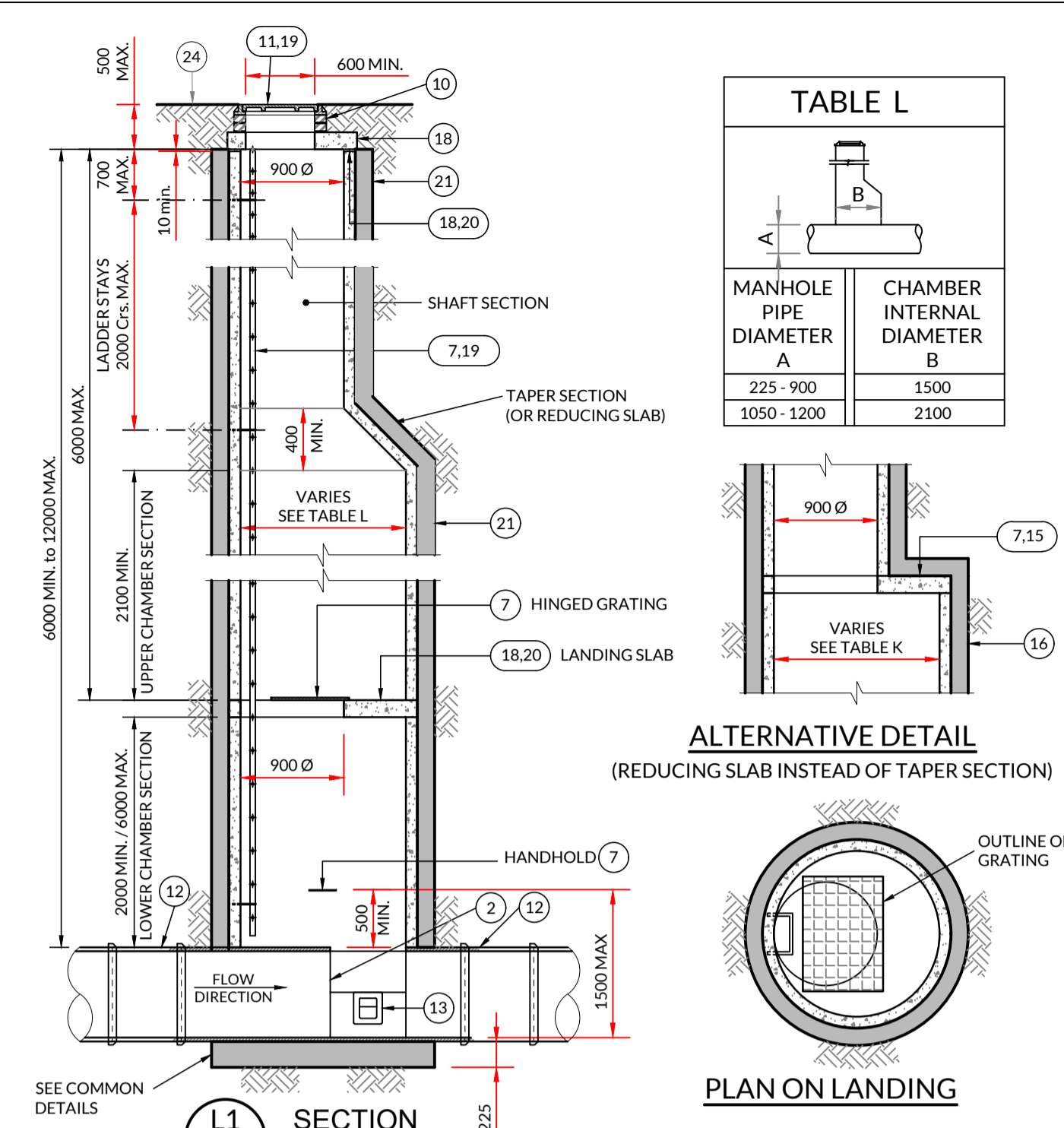

MANHOLE TYPE L
 6m < DEPTH TO INVERT < 12m

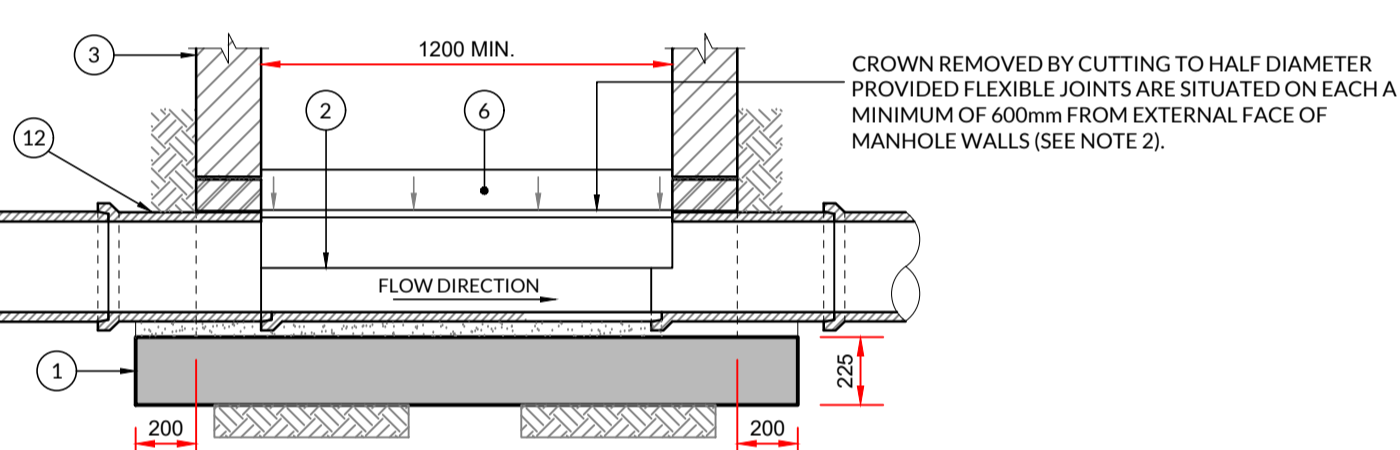

ALTERNATIVE METHOD OF FORMING CHANNEL THROUGH MANHOLE
 SCALE 1:25

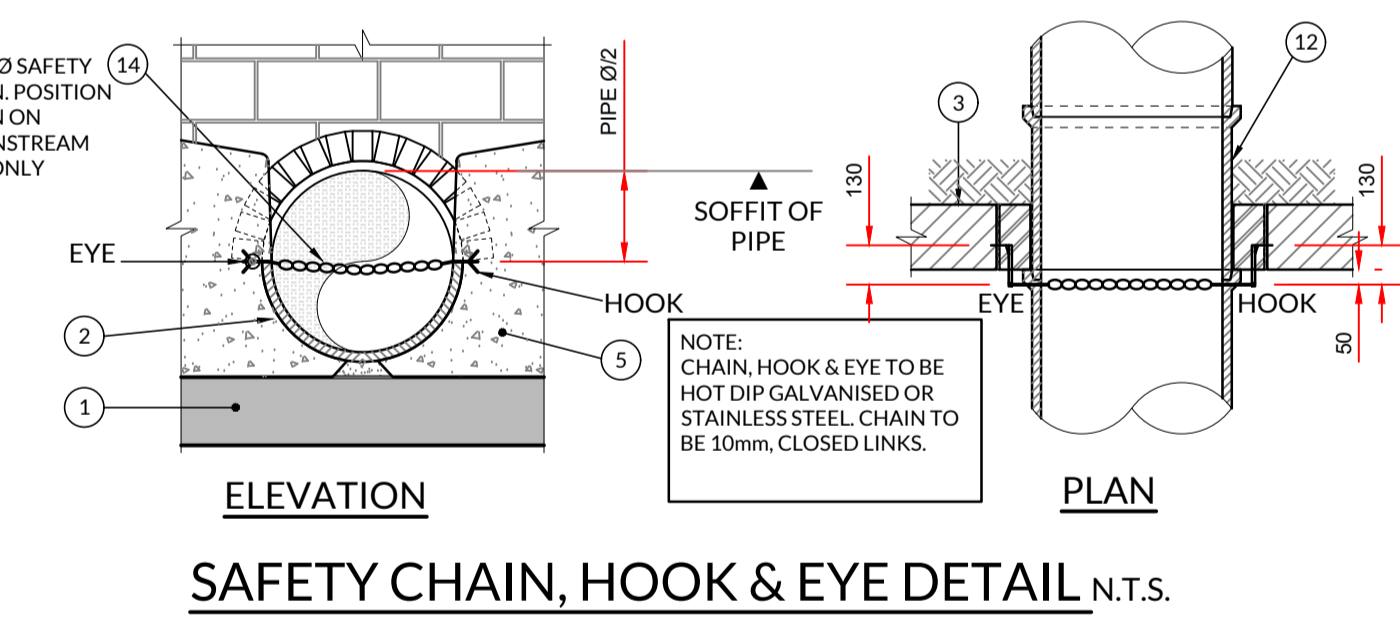

SAFETY CHAIN, HOOK & EYE DETAIL N.T.S.

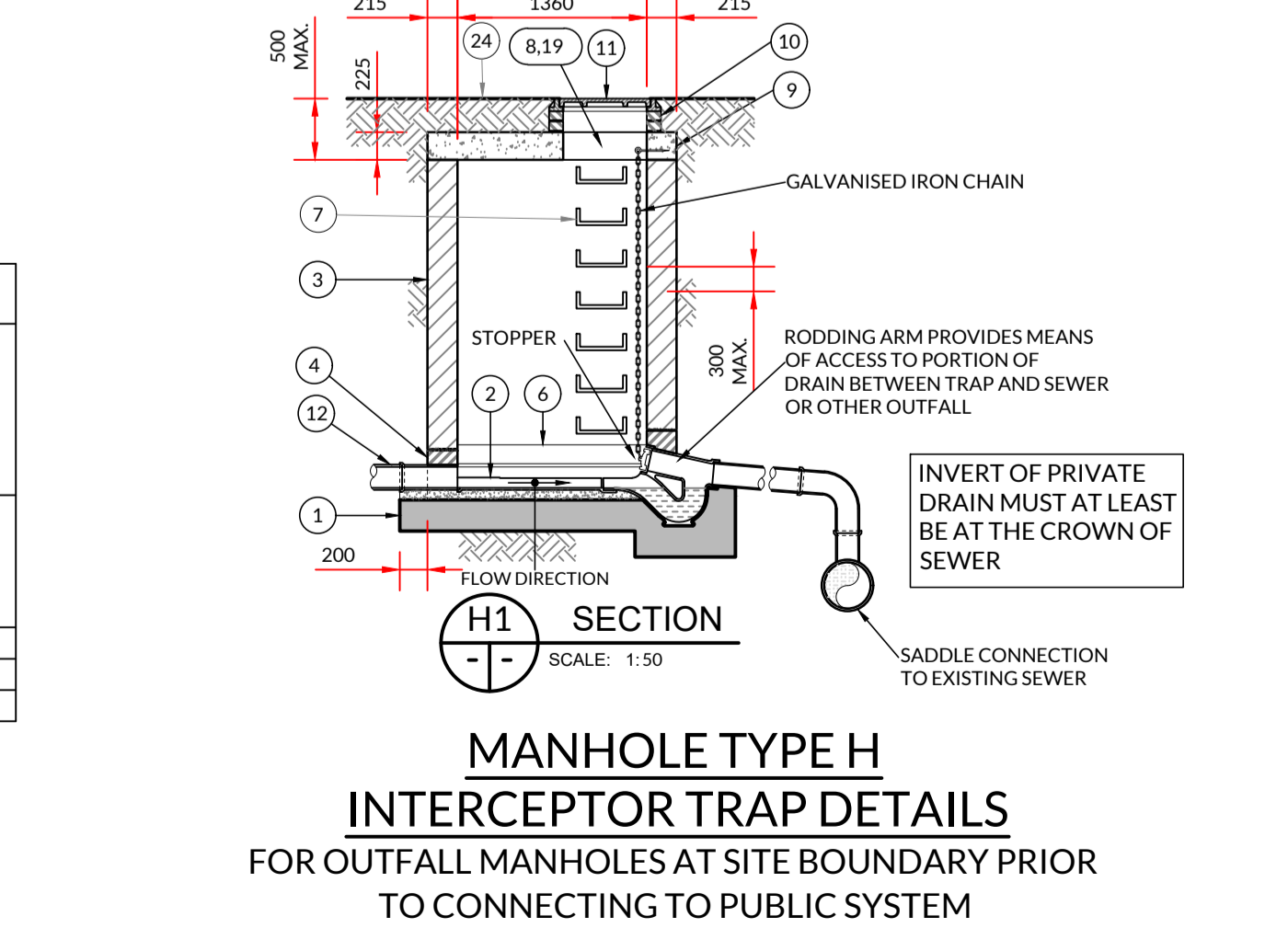

MANHOLE TYPE H
INTERCEPTOR TRAP DETAILS
 FOR OUTFALL MANHOLES AT SITE BOUNDARY PRIOR TO CONNECTING TO PUBLIC SYSTEM

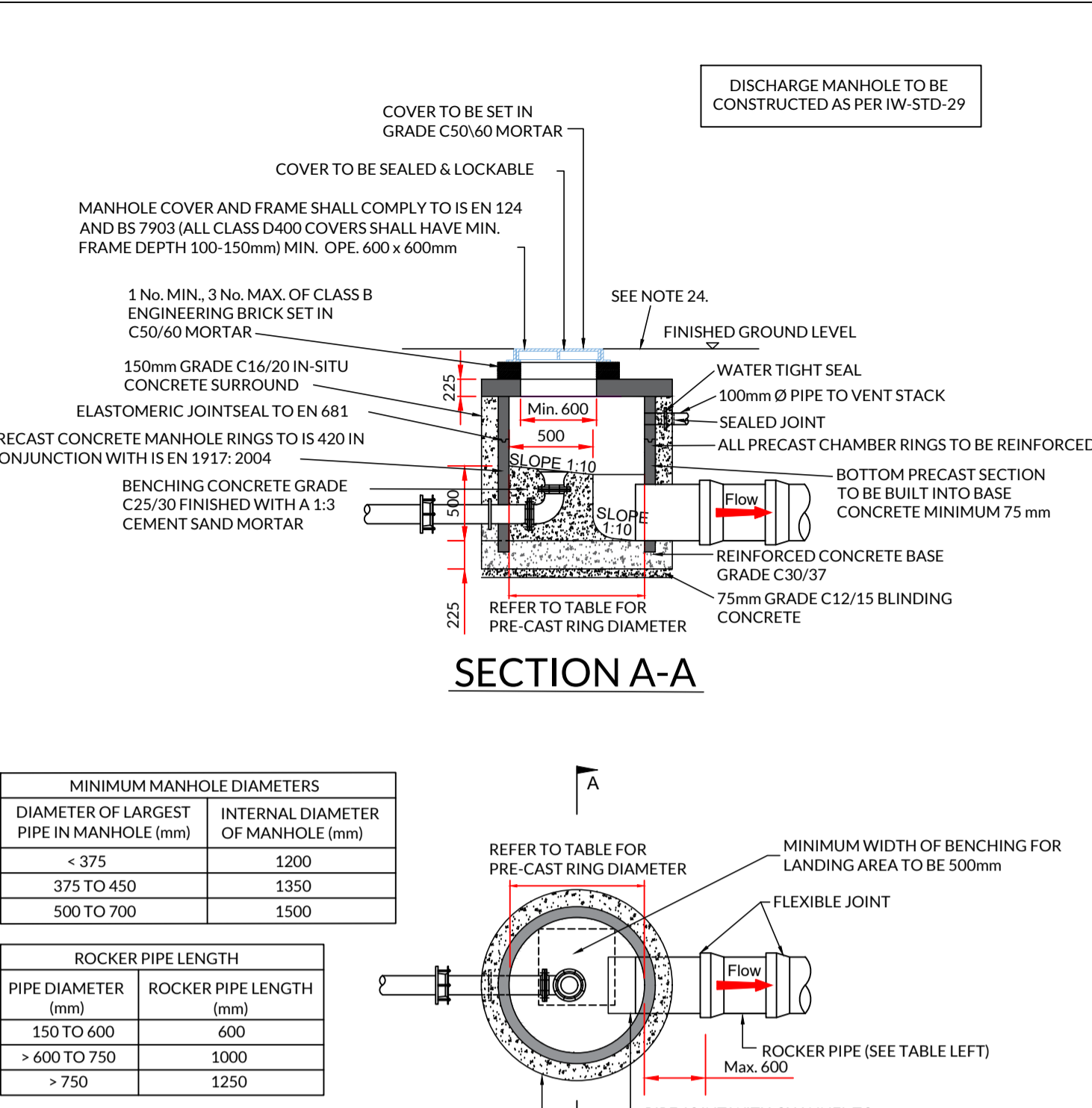

RISING MAIN DISCHARGE MANHOLE
 NOT TO SCALE

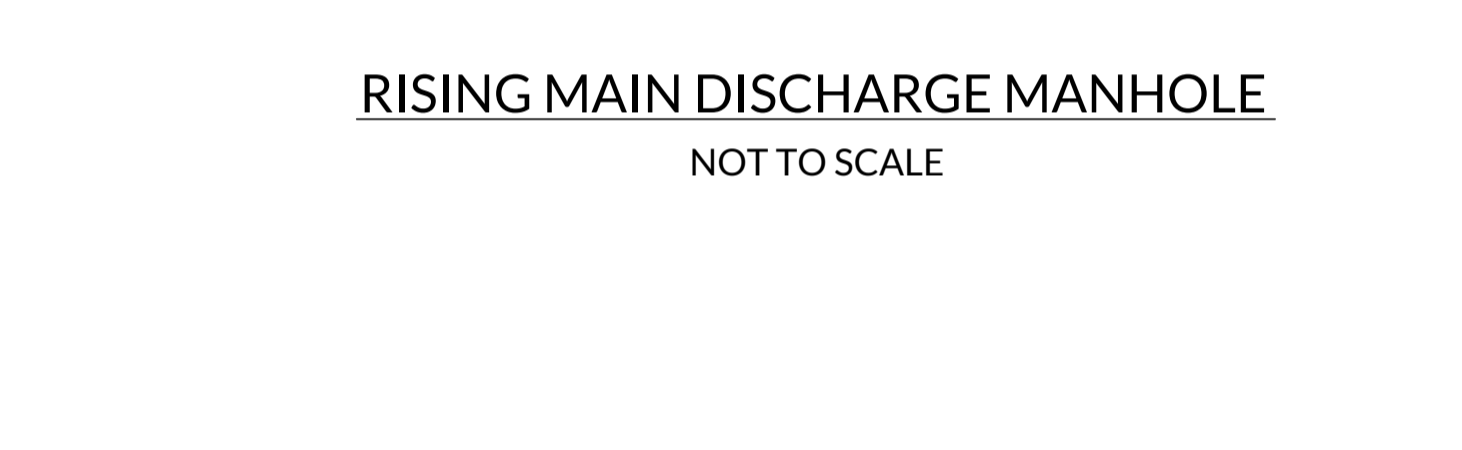

TYPICAL PETROL INTERCEPTOR DETAIL
 SCALE 1:25

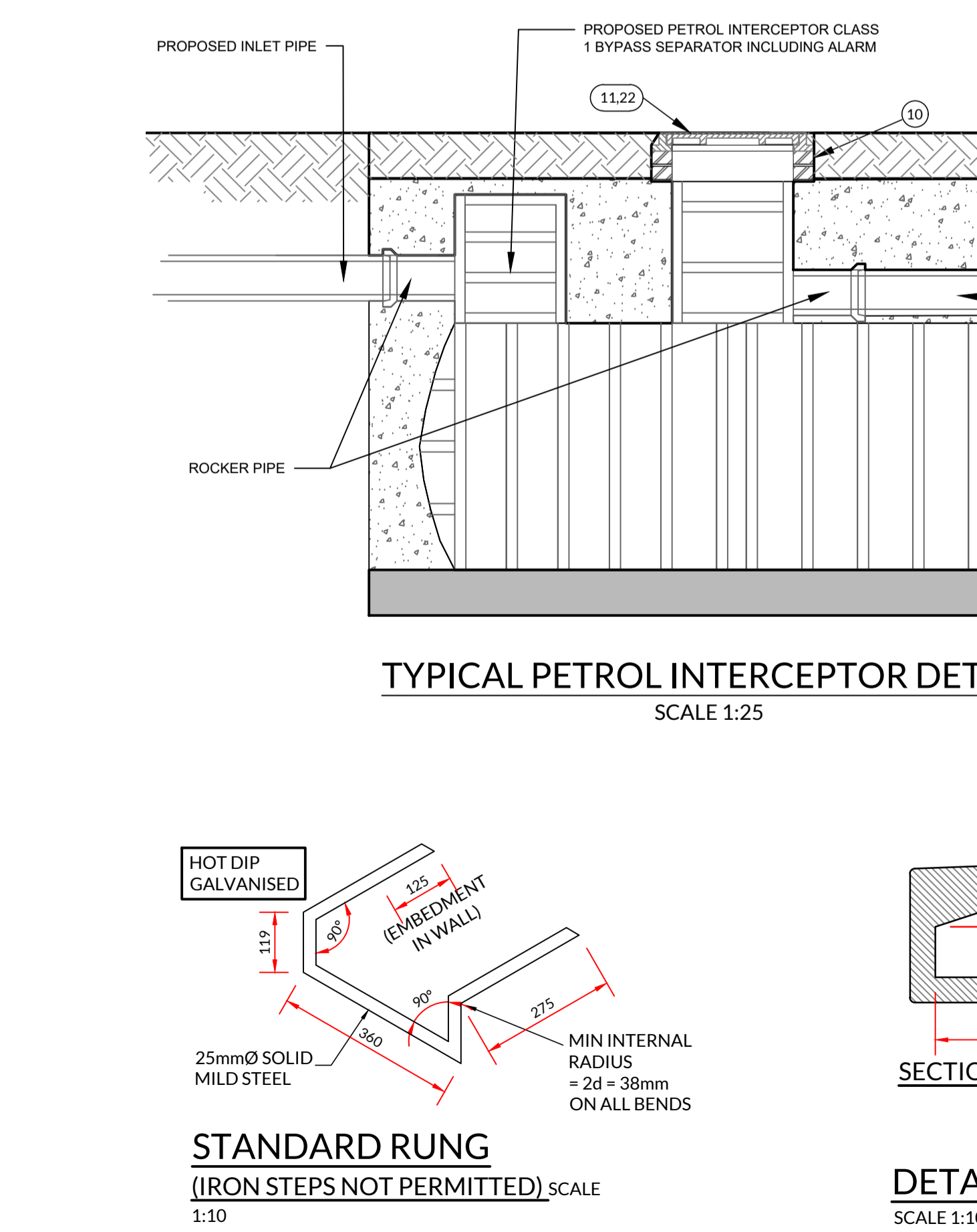

STANDARD RUNG
 (IRON STEPS NOT PERMITTED) SCALE 1:10
DETAILS OF TOE HOLD
 SCALE 1:10

- LEGEND:**
- 225mm REINFORCED CONCRETE BASE, GRADE 30/37.
 - PERFORMED HALF CIRCLE CHANNEL PIPES, THE PIPELINE MAY, WHERE PRACTICABLE BE LAID THROUGH THE MANHOLE & THE CROWN CUT OUT TO HALF DIAMETER, PROVIDED FLEXIBLE JOINTS ARE SITUATED ON EACH SIDE NO FURTHER THAN 600mm FROM INNER FACE OF THE MANHOLE WALL.
- NOTE: WHERE PIPE DIAMETER CHANGES A MANHOLE, PIPE TO LINE UP MANHOLE CONSTRUCTION:**
- BLOCK WORK MANHOLE:**
 - SOLID BLOCK WORK TO BE OF HIGH STRENGTH (20N/mm²) TO IS EN 771.
 - MAXIMUM DEPTH IS 1.20m (THE USE OF BLOCK WORK IN DEEPER MANHOLES WILL BE CONSIDERED BUT SUCH USE WILL REQUIRE DETAILED STRUCTURAL DESIGN AND BE SUBJECT TO IRISH WATER REVIEW)
 - WALLS TO BE FLUSH AND NOT PLASTERED INTERNALLY, INTERNAL LINING OF ENGINEERING BRICK TO IS EN 771-1 TO A HEIGHT OF 1.0m ABOVE BENCHING. ENGINEERING BRICK TO BE BONDED TO BLOCK WORK USING ENGLISH GARDEN WALL BOND.
 - BLOCK WORK SHALL BE EMBEDDED & JOINTED USING MORTAR TO IS EN 998. BEDS & VERTICAL JOINTS TO BE COMPLETELY FILLED WITH MORTAR AS THE BLOCKS ARE LAID.
 - PRE-CAST CONCRETE MANHOLE:**
 - THE UNITS ARE TO COMPLY WITH REQUIREMENTS OF IS EN 1917:2002 AND BS 5911 PART 3.
 - THICKER MANHOLE BASES REQUIRED FOR SEWERS IN EXCESS OF 3.0m DEEP WHERE THE SIZE IS GREATER THAN THE STANDARD MINIMUM SIZE.
 - APPROVED PRE-CAST CONCRETE BASES MAY BE USED INCORPORATING CHANNELS, BENCHING, ETC. SUBJECT TO IRISH WATER REVIEW AND COMPLYING WITH BS 5911-4:2002 IN CONJUNCTION WITH IS EN 1917:2002.
 - IN-SITU CONCRETE MANHOLE:**
 - TO HAVE A MINIMUM WALL AND FLOOR THICKNESS OF 225mm FOR MANHOLE DEPTHS UP TO 3.0m AND 300mm OR MORE WHEN THE MANHOLE DEPTHS EXCEEDS 3.0m.
- RELIEVING ARCH FORMED BY 215x105x65 SOLID ENGINEERING BRICK CLASS A OR B. (RELIEVING ARCHES ARE USED IN BRICK OR BLOCK WORK MANHOLES EXTENDED OVER FULL THICKNESS OF WALLS). A DOUBLE ARCH TO BE FORMED FOR PIPE DIAMETER GREATER THAN 600mm.
 - BENCHING AND PIPE SURROUND - C30/37 CONCRETE.
 - 1:3 CEMENT: SAND MORTAR WITH STEEL TROWEL FINISH AT SLOPE OF 1:30 TOWARDS THE CHANNEL.
 - MANHOLE STEPS TO COMPLY WITH IS EN 13101, TYPE D, CLASS 1, GALVANIZED MILD STEEL RUNGS, 20mm DIAMETER, SHALL BE PROVIDED WITH PLASTIC ENCAPSULATED FINISH. STEP RUNGS ARE TO BE PROVIDED IN MANHOLES WHERE THE DEPTH FROM GROUND TO THE SOFFIT OF THE PIPE IS UP TO 3.0m. FIXED LADDERS ARE REQUIRED IN MANHOLES WHERE THE DEPTH FROM GROUND TO THE SOFFIT OF THE PIPE EXCEEDS A DEPTH OF 3.0m AND UP TO 6.0m, AND SHALL COMPLY WITH IS EN 14396. ALL LADDER RUNGS, HANDRAILS, SAFETY CHAINS ETC. TO COMPLY WITH BS EN ISO 1461:2009 OR EQUIVALENT.
 - 600mm SQUARE OPE IN ROOF.
 - MANHOLE ROOFS SHALL CONSIST OF REINFORCED CONCRETE SLAB OF IN-SITU CONCRETE 30/37, WITH A MINIMUM THICKNESS OF 225mm DESIGNED TO CARRY ALL LIVE AND DEAD LOADS. ALTERNATIVELY, APPROVED PRE-CAST CONCRETE ROOF SLABS MAY BE USED SUBJECT TO IRISH WATER REVIEW AND COMPLIANCE WITH BS 5911 PART 4:2002, IN CONJUNCTION WITH IS EN 1979:2002 AND IS 420:2004.
 - 1 TO 3 MAX. COURSES OF CLASS B ENGINEERING BRICKS TO IS EN 771:2011 SET IN C 50/60 MORTAR.
 - MANHOLE COVER AND FRAME SHALL COMPLY TO IS EN 124 AND BS 7903 (ALL CLASS D400 COVERS SHALL HAVE MIN. FRAME DEPTH 100-150mm). MIN. OPE 600x600mm. COVER TO BE SET IN C 50/60 MORTAR.
 - SHORT LENGTH PIPE & PIPE JOINT EXTERNAL TO MAHOLES SHALL NOT EXCEED 600mm FROM THE INNER FACE OF THE MANHOLE WALL.
 - TOE HOLES Ø225mm MINIMUM IN DEPTH & GALVANIZED SAFETY RAILINGS TO BE PROVIDED IN BENCHING OF SEWERS GREATER THAN 525mm Ø & DEPTH TO INVERT > 3.0m FOR ACCESS TO INVERT.
 - STAINLESS STEEL CHAIN IS TO BE PROVIDED ON PIPES THAT EXCEEDED 450mm Ø, COMPLYING WITH BS4942 PART 2 OR EQUIVALENT.
- NOTES:**
- ALL MANHOLES SHALL BE WATER TIGHT TO THE SATISFACTION OF THE ENGINEER.
 - FORMWORK TO REINFORCED CONCRETE & MASS CONCRETE SHALL COMPLY WITH IS EN 1992-1-1.
 - FINISH TO THE TOP OF SLAB SHALL COMPLY WITH TYPE A SECTION 4.2.7, BS 8110 PART 1:1997.
 - PLAN DIMENSIONS OF MANHOLES ARE BASED ON BLOCK WORK HAVING A CO-ORDINATING SIZE OF 450x225x100. FORT PIPE DIAMETER OF > 750mm USE MANHOLE WITH INTERNAL DIAMETER SIZE = PIPE SIZE + 1.0m + 300mm.
 - MANHOLES ARE DESIGNED TO BS EN 752:2017 & WALL THICKNESS TO IS EN 1996-1-1. BLOCK WORK DESIGN CODE TAKING GRANULAR FILL PRESSURE & H.B. SURCHARGE.
 - REINFORCEMENTS TO SLABS TO ENGINEERS DETAILS.
- FOR MANHOLES > 3m DEPTH TO INVERT USE C30/37 IN-SITU CONCRETE, REINFORCING MESH REF. A393 TO BE FIXED AT MID POINT OF WALL. ADDITIONAL REINFORCEMENT TO BE SUPPLIED OVER PIPE CROWN.**
- PRECAST MANHOLES, CHAMBER WALLS & COVER SLAB TO BE GALVANIZED TO IS EN 1917 & IS 420:2004.
 - MANHOLE OPENINGS TO BE SITUATED FURTHEST FROM THE NEAREST CARRIAGEWAY. MANHOLE STEPS-ACCESS TO BE POSITIONED TO ALLOW VIEWING OF ONCOMING TRAFFIC.
 - FOR BEDDING AND CEILING OF CHAMBER RINGS, THE TOP RING (TO PRECAST OVER SLAB) & BOTTOM RING TO BE BEDDED WITH CEMENT MORTAR FOR INTERMEDIATE RINGS. JOINTS TO BE SEALED WITH APPROVED PREFORMED JOINTING STRAP.
 - PRECAST MANHOLES TO BE SURROUNDED WITH A MINIMUM OF 150mm THICK GRADE C16/20 CONCRETE.
 - 225mm GRADE C 25/30 CONCRETE SURROUND.
 - 75mm GRADE C 12/15 BLINDING CONCRETE.
 - ANY SPECIAL ROAD REINSTATEMENT AROUND COVER AND FRAME SHALL BE TO ROAD AUTHORITY'S REQUIREMENTS. NEW ROAD CONSTRUCTION AND SURFACE FINISH TO BE ROAD AUTHORITY'S REQUIREMENTS. EXISTING ROAD REINSTATEMENT TO COMPLY WITH CURRENT VERSION OF "GUIDELINE FOR MANAGING OPENINGS IN PUBLIC ROADS" BY THE DEPT. OF TRANSPORT, TOURISM & SPORT, OR TRANSPORT INFRASTRUCTURE IRELAND REQUIREMENTS.
 - PRECAST CONCRETE MANHOLE RINGS TO IS 420 IN CONJUNCTION WITH EN 1917:2004.

NOTES:

- FIGURED DIMENSIONS ONLY TO BE TAKEN FROM THIS DRAWING.
- ALL DRAWINGS TO BE CHECKED BY THE CONTRACTOR ON SITE.
- ENGINEER/EMPLOYERS REPRESENTATIVE, AS APPROPRIATE, TO BE INFORMED BY THE CONTRACTOR OF ANY DISCREPANCIES BEFORE ANY WORK COMMENCES.
- THE CONTRACTOR SHALL UNDERTAKE A THOROUGH CHECK FOR THE ACTUAL LOCATION OF ALL SERVICES, UTILITIES, ABOVE AND BELOW GROUND, BEFORE ANY WORK COMMENCES.
- ALL LEVELS SHOWN RELATE TO ORDNANCE SURVEY DATUM AT MALIN HEAD.
- MANHOLE DETAILS FOR FOUL SEWER TO BE IN ACCORDANCE WITH IRISH WATER STANDARD DETAILS AND CODE OF PRACTICE - IRISH WATER DETAILS & REQUIREMENTS WILL TAKE PRECEDENCE.

Rev	Date	Description	By	Chkd.
D01	12/07/2023	Draft Planning	RM	RB

Client: Galway County Council

Project: Proposed Residential Development
 Baile an Chlair
 Claregalway

Title: Standard Manhole Details.
 Sheet 2 of 2

Scale @ A1:	As Shown
Prepared by:	Checked:
RM	RB
Date:	July 2023
Project Director:	Brian Carroll
Drawing Status:	Draft Planning

TOBIN
 CONSULTING ENGINEERS

Galway Office
 Fairgreen House, Fairgreen Road,
 Galway,
 H91 AXK8,
 Ireland.

Tel: +353 (0)91 565 211
 www.tobin.ie

DRAFT

TOBIN Consulting Engineers will not be liable for any use of this document for any purpose other than that for which it was originally prepared and intended. Except where specifically and expressly agreed in writing by TOBIN Consulting Engineers, no copyright notice, or any other document may be reproduced or transmitted in any form and this document shall not be relied upon by any third party for any purpose.

Revised:
 Drawing No: 11171-2018D01