

UNDER ROADS/HARDSTANDINGS/FOOTPATHS  
COVER > 1.2m

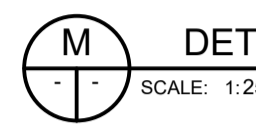

CONCRETE BEDDING

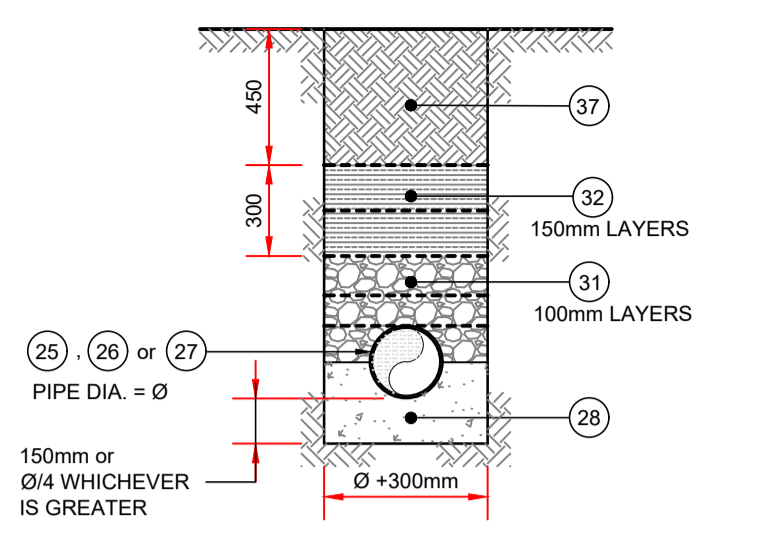

UNDER LANDSCAPED AREAS  
COVER > 0.9m

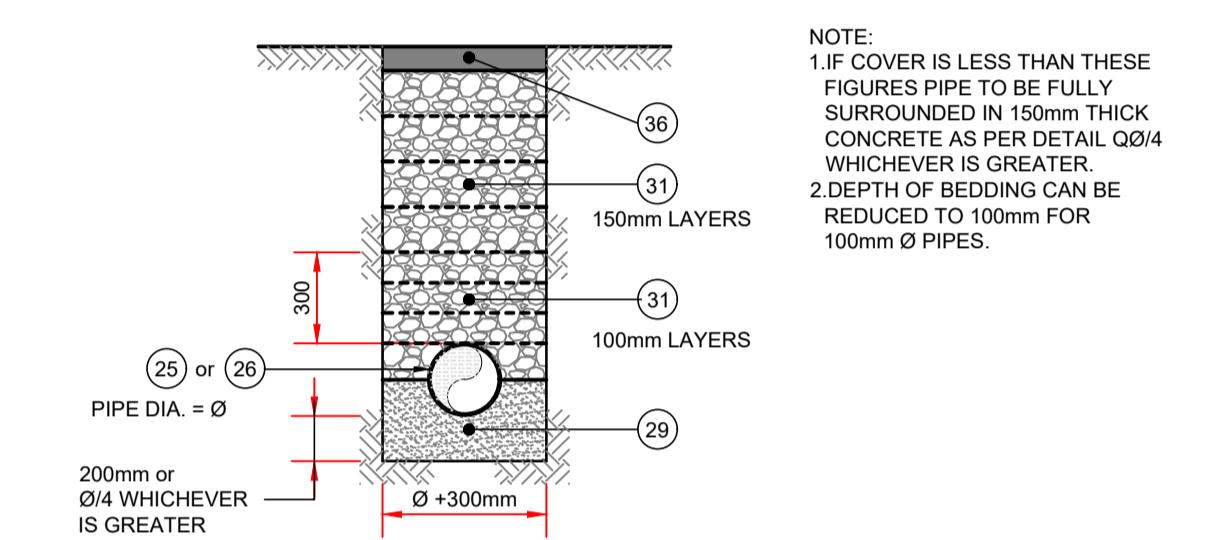
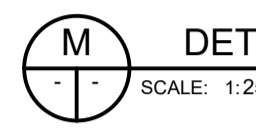

UNDER ROADS/HARDSTANDINGS/FOOTPATHS  
COVER > 1.2m

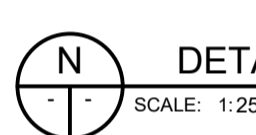

GRANULAR BEDDING

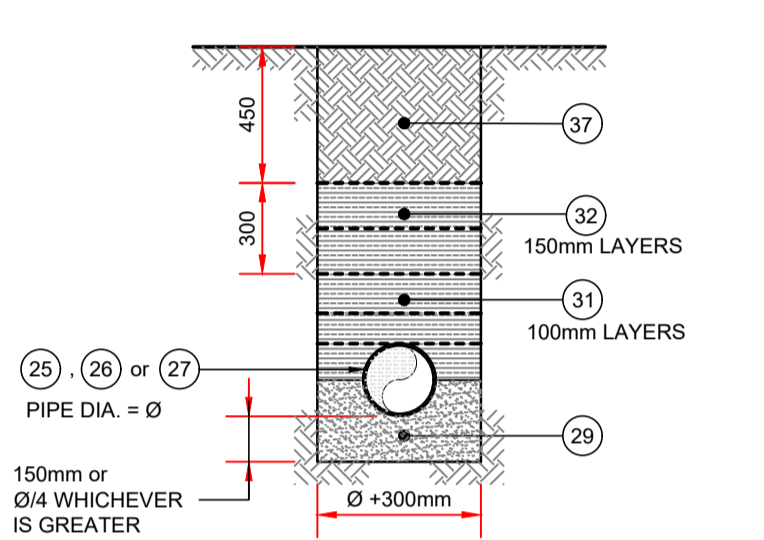

UNDER LANDSCAPED AREAS  
COVER > 0.9m

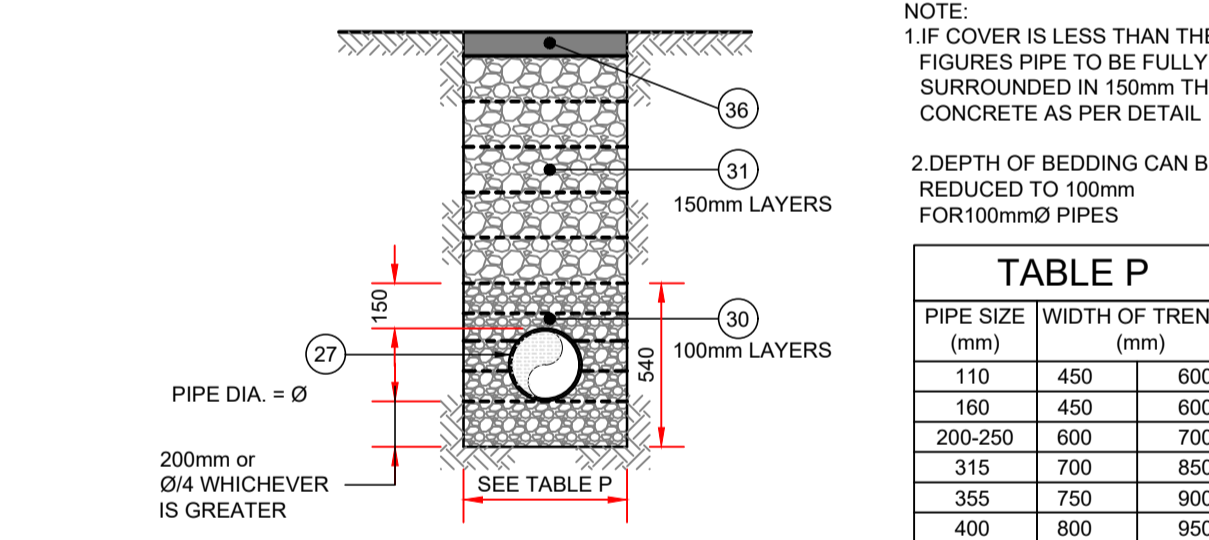
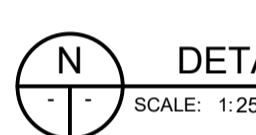

UNDER ROADS/HARDSTANDINGS/FOOTPATHS  
COVER > 1.2m

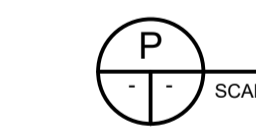

UPVC PIPES BEDDING

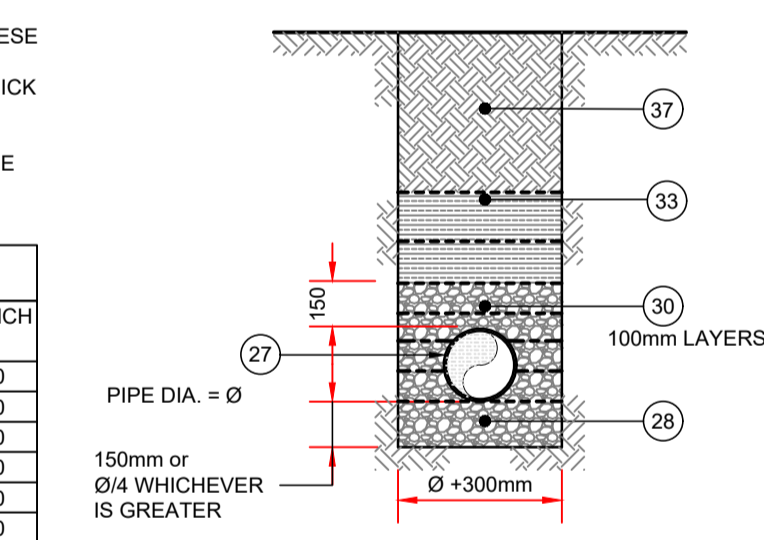

UNDER LANDSCAPED AREAS  
COVER > 1.2m

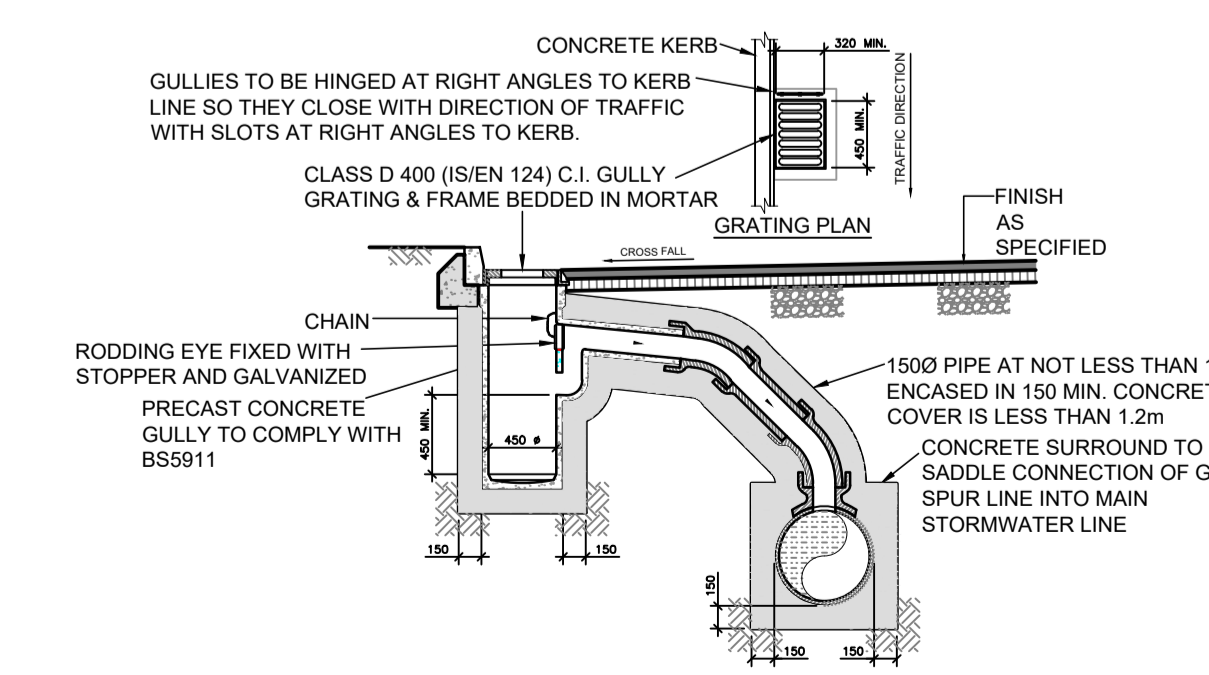
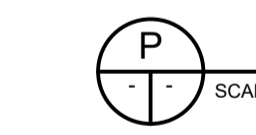

PRECAST ROAD GULLY DETAILS  
A1 SCALE 1:50  
A3 SCALE 1:100

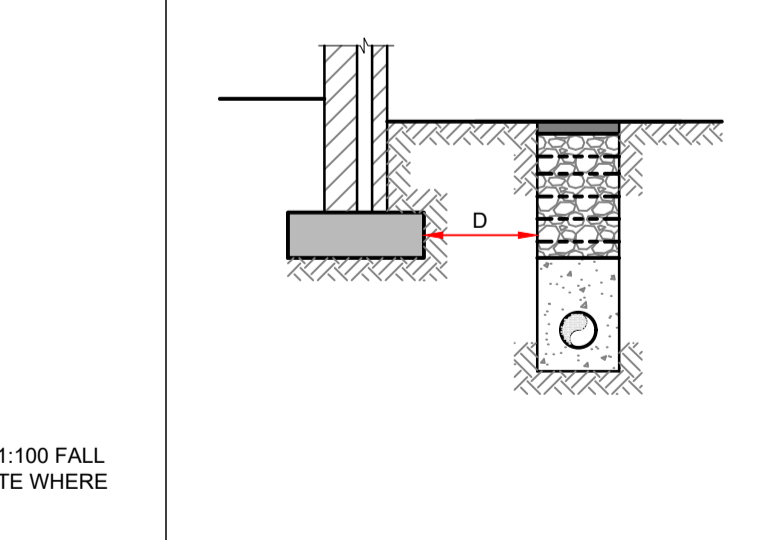

WHERE 'D' IS LESS THAN 1m  
CONCRETE FILL TO LEVEL OF FOUNDATION BOTTOM)

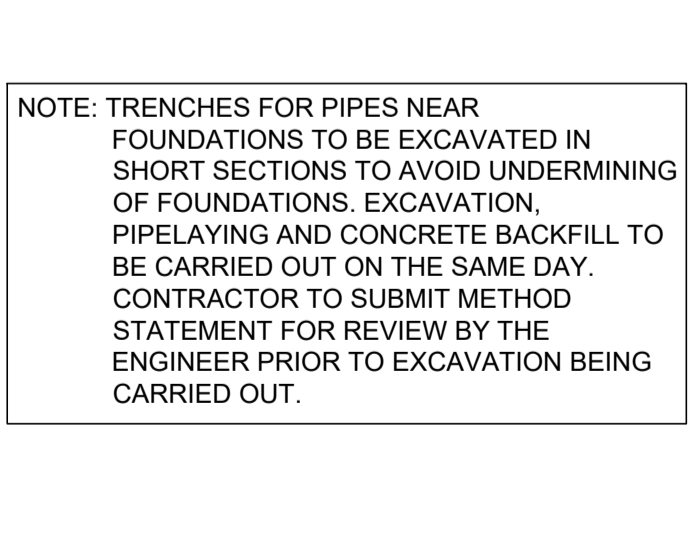

WHERE 'D' IS 1m OR MORE  
CONCRETE FILL TO WITHIN D-150mm OF LEVEL OF FOUNDATION BOTTOM

CONCRETE PIPE LAID NEAR FOUNDATIONS

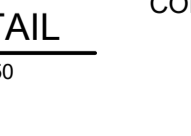

CONCRETE PIPE ENCASEMENT

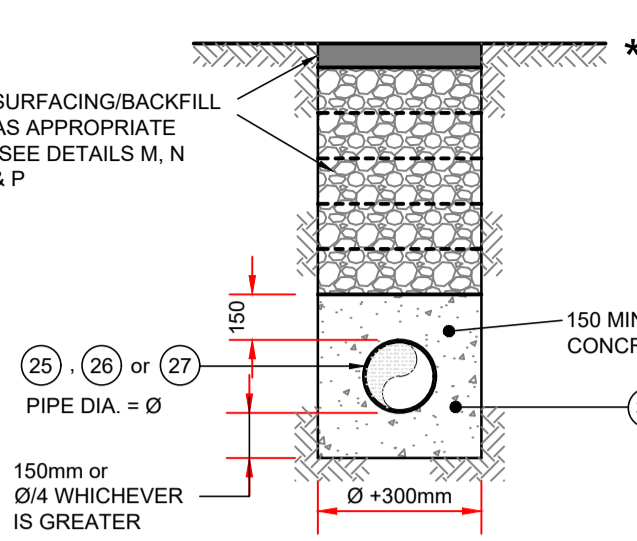

CONCRETE PIPE ENCASEMENT  
DETAIL



CONCRETE ENCASEMENT

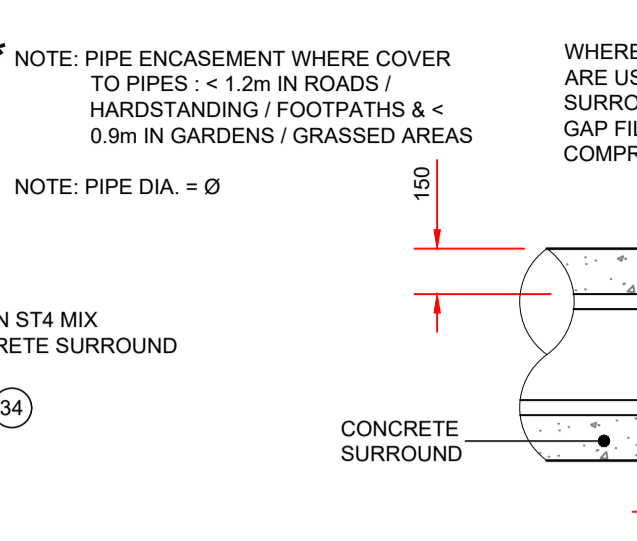

JOINT IN CONCRETE SURROUND  
DETAIL



CONCRETE ENCASEMENT

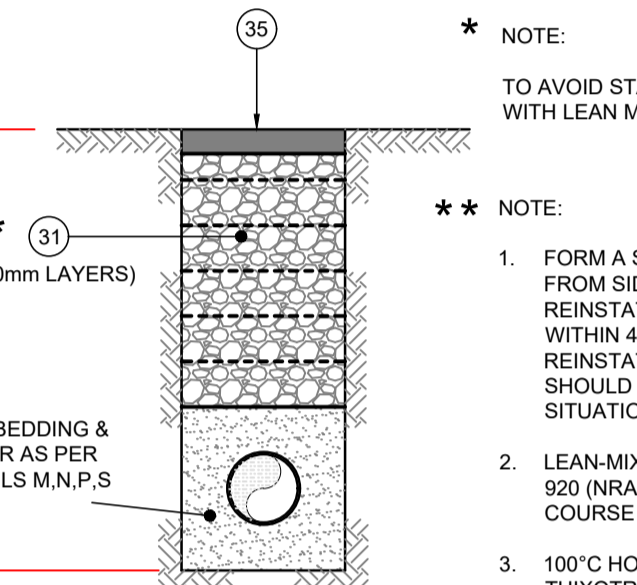

STAGE 1  
LEAVE FOR 6 MONTHS TO CONSOLIDATE

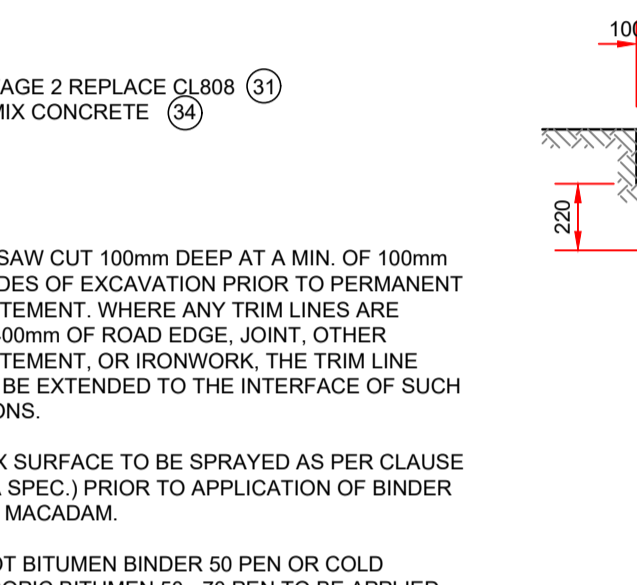

STAGE 2  
DIG OUT SURFACING & TOP 220mm OF CL808 MATERIAL (31) & REPLACE WITH NEW WIDER SURFACING ON 220mm LAYER OF LEAN-MIX CONCRETE (34)

REINSTATEMENT OF PIPE TRENCH IN EXISTING ROAD



TYPE 'A' TYPE 'B'  
TYPE 'C' TYPE 'D'

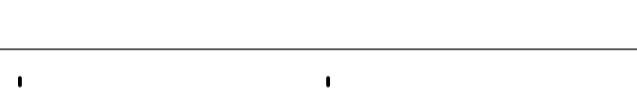

REINSTATEMENT OF PIPE TRENCH IN EXISTING ROAD

- GENERAL NOTES**
- IN SOFT CONDITIONS CBR<5 THE MATERIAL SHOULD BE EXCAVATED AND DISPOSED IN ACCORDANCE WITH THE WASTE MANAGEMENT ACT AND CLAUSE 804 MATERIAL IN ACCORDANCE WITH THE NRA SPECIFICATION FOR ROAD WORKS. SHALL REPLACE THE EXCAVATED MATERIAL WRAPPED IN GEO-TEXTILE SHEETING. ALTERNATIVELY SPECIAL PIPE SUPPORT ARRANGEMENTS INCLUDING PILING ETC. MAY BE REQUIRED WHERE THE SOFT MATERIAL IS EXCESSIVE. SUCH ARRANGEMENTS SHALL BE ASSESSED BY IRISH WATER BEFORE ADVANCING WITH THE WORK.
  - PIPES SHALL NOT BE SUPPORTED ON STONES, ROCKS OR HARD OBJECT AT ANY POINT ALONG THE TRENCH. ROCK SHALL BE EXCAVATED TO A DEPTH OF 150mm BELOW THE ACTUAL DEPTH OF THE TRENCH WITH THE VOID FILLED WITH CLAUSE 804 MATERIAL IN ACCORDANCE WITH THE NRA SPECIFICATION FOR ROAD WORKS. THE GRANULAR MATERIAL SHALL BE LAID ABOVE THIS VOID BACKFILL MATERIAL.
  - NON DEGRADABLE MARKER TAPE SHOULD BE INSTALLED AT TOP OF PIPE BEDDING LAYER. IN CASE OF NON METAL PIPE MATERIAL THE MARKER SHOULD INCORPORATE A TRACE WIRE WHICH IS LINKED TO THE FITTINGS AND AND TERMINATED AT THE PLUMBING STATION AND DISCHARGE MANHOLE.
  - TRENCH WIDTHS FOR PIPE SIZES 80mm AND LESS MAY BE <math>< 500\text{mm}</math> SUBJECT TO CONSIDERATION BEING GIVEN TO THE TRENCH DEPTH, HAS. CONSTRUCTION ACCESS REQUIREMENTS.
  - THE HAUNCHES AND SURROUNDS TO BE FORMED USING FORM WORK AND PROVIDE A ROUGH CAST.
  - EXPANSION JOINTS IN THE CONCRETE SHALL BE PROVIDED AT ALL PIPE JOINTS TO ALLOW FOR PIPE FLEXIBILITY. COMPRESSIBLE FILLER BOARD TO BE IN ACCORDANCE WITH BS EN 622-1 AND BS EN 622-4 AND TO BE 18mm THICK.
  - POLYETHYLENE PIPES SHALL BE WRAPPED IN PLASTIC SHEETING HAVING A COMPOSITION IN ACCORDANCE WITH BS 6076 BEFORE BEING CAST INTO CONCRETE.
  - BITUMINOUS MATERIAL SHALL NOT BE PUT IN CONTACT WITH PE OR PVC PIPES.

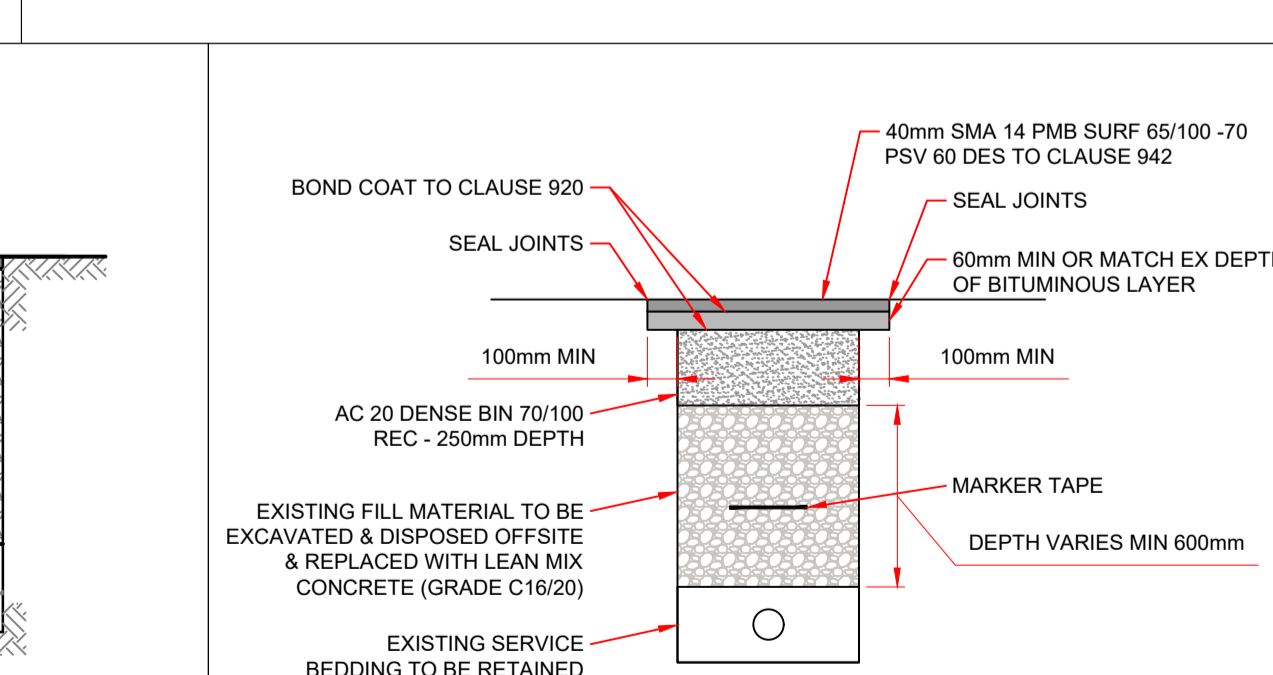

TYPICAL SERVICE REINSTATEMENT  
DETAIL - ASPHALT ROAD

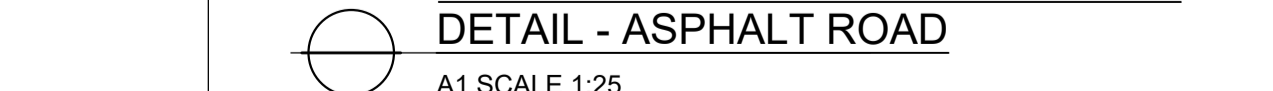

TYPICAL SERVICE REINSTATEMENT  
DETAIL - ASPHALT ROAD

- NOTES:**
- 225mm THICK C30/37 MASS CONCRETE FOUNDATIONS.
  - PREFORMED HALF CIRCLE CHANNEL PIPES, THE PIPELINE MAY, WHERE PRACTICABLE BE LAID THROUGH THE MANHOLE & THE CROWN CUT OUT TO HALF DIAMETER. DIVIDED FLEXIBLE JOINTS ARE SITUATED ON EACH SIDE NO FURTHER THAN 600mm FROM INNER FACE OF THE MANHOLE WALL.
  - MANHOLE CONSTRUCTION:
    - FOR SURFACE WATER MANHOLES HIGH-DENSITY BLOCKS 20N STRENGTH TO I.S. EN 771 OR C30/37 INSITU CONCRETE TO IS EN 206.
    - BLOCK WORK SHALL BE EMBEDDED & JOINTED USING MORTAR TO IS 406. BEDS & VERTICAL JOINTS TO BE COMPLETELY FILLED WITH MORTAR AS THE BLOCKS ARE LAID.
    - ALL FOUL MANHOLES MUST BE FACED IN SOLID ENGINEERING BRICK (MIN CLASS 'A' OR 'B') OR INSITU CONCRETE FOR 1m ABOVE BENCHING LEVEL. BRICK TO BE BONDED TO BLOCK WORK USING GARDEN WALL BOND.
    - JOINTS SHALL BE FLUSH AND POINTED AS THE WORK PROCEEDS.
    - MAX DEPTH OF BLOCKWORK MANHOLE IS 1.2m (THE USE OF BLOCK IN DEEPER MANHOLES WILL BE CONSIDERED BUT SUCH WILL REQUIRE DETAILED STRUCTURAL DESIGN AND WRITTEN APPROVAL FROM IRISH WATER).
    - RELIEVING ARCH FORMED BY 215 X 103 X 65 SOLID ENGINEERING BRICK CLASS 'A' OR 'B'. RELIEVING ARCHES USED IN BRICK OR BLOCK WORK MANHOLES EXTEND OVER FULL THICKNESS OF WALL A DOUBLE ARCH IS TO BE FORMED FOR PIPE DIAMETER GREATER THAN 600mm.
    - BENCHING & PIPE SURROUND - C30/37 CONCRETE.
    - BENCHING FINISHED IN SAND-CEMENT MORTAR WITH SMOOTH TOWEL FINISH, AT 1 IN 30 SLOPE TOWARDS CHANNEL.
    - STANDARD RUNGS AT 300mm c/c VERTICALLY & GALVANISED TO THE LATEST VERSION OF BS 729 OR EQUIVALENT. NOTE IRONS ARE NOT ACCEPTABLE.
    - 600mm SQUARE OPE IN ROOF.
    - PRECAST R.C ROOF SLAB SHALL BE 200mm THICK CLASS C30/37 WITH 40mm COVER TO STEEL DESIGNED TO BS 8100 TO TAKE FULL TRAFFIC LOADING.
    - 1 TO 2 COURSES OF SOLID ENGINEERING BRICKS CLASS 'B' TO IS 91.1983 SET IN C50/60 MORTAR.
  - CLASS D400 OR E600 MANHOLE COVER AND FRAME TO IS EN 124. 150mm DEEP FRAME FOR ROADS & 100mm DEEP FOR FOOTPATHS & GREEN AREAS. NON-ROCK DESIGN. CLOSED KEYWAYS, MANUFACTURED FROM SPHERICAL GRAPHITE CAST IRON (DUCTILE CAST IRON) 600 X 600 (6000) CLEAR OPENINGS. COVER & FRAME COMBINED IN BITUMEN OR OTHER APPROVED MATERIAL. COVER TO HAVE MINIMUM MASS OF 140kg/m<sup>2</sup> FRAME BEARING AREA SHALL BE DESIGNED TO PREVENT COVERS FALLING INTO MANHOLE. FRAMES SHALL BE BEDDED ON APPROVED MORTAR TO MANUFACTURERS INSTRUCTIONS.
  - SHORT LENGTH PIPE & PIPE JOINT EXTERNAL TO MANHOLE WALL NOT EXCEED 600mm FROM THE INNER FACE OF MANHOLE WALL.
  - TOE HOLES OF 230mm MINIMUM DEPTH & GALVANISED SAFETY RAILINGS TO BE PROVIDED IN BENCHING OF SEWERS GREATER THAN 525mmØ & DEPTH TO INVERT >3M FOR ACCESS TO INVERT.
  - A STAINLESS STEEL CHAIN IS TO BE PROVIDED ON PIPES THAT EXCEED 450mmØ. COMPLYING WITH BS 4942 PART 2 OR EQUIVALENT.
  - WHEN THE DEPTH OF MANHOLES TO INVERT IS GREATER THAN 3.0m LADDERS SHALL BE USED. INSTEAD OF RUNGS TO BS 4211 OR EQUIVALENT EXCEPT THAT STRINGERS SHOULD BE NOT LESS THAN 66x12mm. IN SECTIONS A RUNGS 25mm IN DIAMETER. FIXED LADDERS SHOULD MEET THE DIMENSIONAL REQUIREMENTS OF BS4211 OR EQUIVALENT. DISTANCE FROM THE TOP RUNG OF THE LADDER TO GROUND LEVEL SHOULD NOT EXCEED 500mm.
  - LADDER STRINGERS SHOULD BE ADEQUATELY SUPPORTED FROM THE MANHOLE WALL AT INTERVALS OF NOT MORE THAN 2.0m. STRINGERS SHOULD BE BOLTED TO CLEATS TO FACILITATE RENEWAL.
  - ALL LADDER RUNGS, HANDRAILS, SAFETY CHAINS ETC. SHALL BE HOT DIPPED GALVANISED TO BS 729 OR EQUIVALENT.
  - PIPE SHOULD BE CUT FLUSH WITH THE INSIDE SURFACE OF THE MANHOLE WALL SO THAT CHANNEL EXTENDS THE FULL LENGTH OF THE MANHOLE.
  - POSITION OF 910 SQUARE OPE IN INTERMEDIATE ROOF SLAB.
    - ALL MANHOLES SHALL BE WATERTIGHT TO THE SATISFACTION OF THE ENGINEER.
    - FORMWORK TO REINFORCED CONCRETE & MASS CONCRETE SHALL COMPLY WITH CLASS 2 SECTION 6.2.7, BS 8110 PART 1:1987.
    - FINISH TO THE TOP OF SLABS SHALL COMPLY WITH TYPE A SECTION 6.2.7, BS8110, PART 1987.
    - PLAN DIMENSIONS OF MANHOLES ARE BASED ON BLOCKWORK HAVING A CO-ORDINATE OF 450 X 225 X 100. FORT PIPE DIAMETER OF >750mm USE MANHOLE WITH INTERNAL DIAMETER SIZE = PIPE SIZE +1m +300mm
    - MANHOLES ARE DESIGNED TO BS8005 & WALL THICKNESS TO IS325. BLOCK WORK DESIGN CODE TAKING GRANULAR FILL PRESSURE & HB SURCHARGE.
    - REINFORCEMENT TO SLABS ENGINEERS DETAILS.
  - FOR MANHOLES >3m DEPTH TO INVERT USE C30/37 INSITU CONCRETE. REINFORCING MESH REF. A393 TO BE FIXED AT MID POINT OF WALL. ADDITIONAL REINFORCEMENT TO BE SUPPLIED OVER PIPE CROWN.
  - PRECAST MANHOLES, CHAMBER WALLS & COVER SLAB TO BE CONSTRUCTED TO IS EN 1917 & IS 420:2004
  - MANHOLE OPENINGS TO BE SITUATED FURTHEST FROM THE NEAREST GARRAGEWAY. MANHOLE STEPS/ACCESS TO BE POSITIONED TO ALLOW VIEWING OF ONCOMING TRAFFIC
  - FOR BEDDING & SEALING OF CHAMBER RINGS, THE TOP RING (TO PRECAST OVER SLAB) & BOTTOM RING TO BE BEDDED WITH CEMENT MORTAR. FOR INTERMEDIATE RINGS, JOINTS TO BE SEALED WITH APPROVED PREFORMED JOINTING STRAP
  - PRECAST MANHOLES TO BE SURROUNDED WITH A MINIMUM OF 150mm THICK GRADE C16/20 CONCRETE.
  - CONCRETE SEWER PIPES WITH SPIGOT & SOCKET JOINTS & RUBBER FITTINGS TO COMPLY WITH IS EN 1916 & IS 6 2004 OR EQUIVALENT STANDARD CLASS M OR CLASS H
  - VIRTIFIED CLAY PIPES AND FITTINGS COMPLYING WITH THE REQUIREMENTS OF IS EN 295-1/2/3 : 1992 OR EQUIVALENT STANDARD CLASS 160 OR CLASS 200
  - UNPLASTICISED POLY(VINYL CHLORIDE (UPVC) PIPES & FITTINGS IN ACCORDANCE WITH THE REQUIREMENTS OF IS424
  - CONCRETE BED & SURROUND MUST BE A MINIMUM 150mm THICK IN-SITU CONCRETE C16/20 & HAUNCHED HALFWAY UP THE BARREL OF THE PIPE.
  - GRANULAR BED AND SURROUND OF RIGID PIPES TO BE EITHER
    - 14mm TO 5mm GRADED AGGREGATE OR.
    - 10mm SINGLE SIZE AGGREGATE
  - GRANULAR BED AND SURROUND & COVER FOR UPVC TO BE:
    - 14mm TO 5mm GRADED AGGREGATE 315mm PIPE DIAMETER
    - 10mm SINGLE SIZED AGGREGATE PIPE DIAMETER <math>< 315\text{mm}</math>

- ALL COMPLYING WITH THE REQUIREMENTS OF IS 5 PART 1:1990, TABLE 7 & SHOULD HAVE A COMPACTION FACTOR VALUE OF NOT GREATER THAN 0.2 WHEN MEASURED IN ACCORDANCE WITH BS 8301: 1985, APPENDIX D. GRANULAR SIDE FILL & COVER TO BE PLACED UNIFORMLY ON EITHER SIDE OF THE PIPE IN LAYERS NOT EXCEEDING 100mm EACH LAYER BEING COMPACTED BY HAND TAMPING UNTIL THE PIPE HAS A MINIMUM COMPACTED COVER OF 150mm.

- NOTES:**
- FIGURED DIMENSIONS ONLY TO BE TAKEN FROM THIS DRAWING.
  - ALL DRAWINGS TO BE CHECKED BY THE CONTRACTOR ON SITE.
  - ENGINEER/EMPLOYERS REPRESENTATIVE, AS APPROPRIATE, TO BE INFORMED BY THE CONTRACTOR OF ANY DISCREPANCIES BEFORE ANY WORK COMMENCES.
  - THE CONTRACTOR SHALL UNDERTAKE A THOROUGH CHECK FOR THE ACTUAL LOCATION OF ALL SERVICES/UTILITIES, ABOVE AND BELOW GROUND, BEFORE ANY WORK COMMENCES.
  - ALL LEVELS SHOWN RELATE TO ORDNANCE SURVEY DATUM AT MALIN HEAD.

Rev	Date	Description	By	Chkd.
PO	22.06.2022	ISSUE FOR PLANNING	JM	SB

Client: Comhairle Chontae na Gaillimhe Galway County Council

Project: Loughrea Fire Station

Title: Standard Pipe Bedding Details

Scale @ A1: As Shown

Prepared by: JM Checked: SB Date: Apr 2021

Project Director: Brian Carroll

Drawing Status: PLANNING

**TOBIN**  
CONSULTING ENGINEERS

TOBIN Consulting Engineers,  
Fairgreen House, Fairgreen Road,  
Galway, Ireland.  
tel: +353-(0)91-565211  
fax: +353-(0)91-565398  
e-mail: galway@tobin.ie  
www.tobin.ie

Tobin Consulting Engineers will not be liable for any use of this document for any purpose other than that for which it was originally prepared and provided. Except where specifically and explicitly agreed in writing by TOBIN Consulting Engineers, no copyright, trademark or other intellectual property rights shall be transferred in any form and this document shall not be relied upon for any other purpose.

Drawing No: 11315-2008 PO

Revision: