

UNDER ROADS/HARDSTANDINGS/FOOTPATHS
COVER > 1.2m

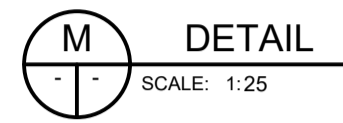

CONCRETE BEDDING

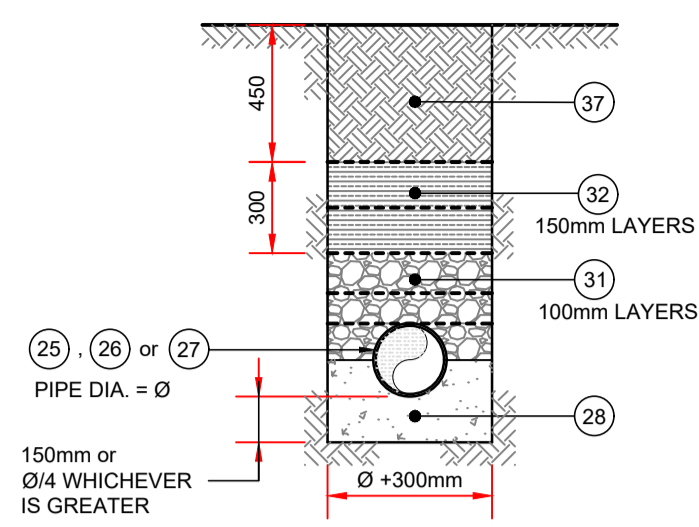

UNDER LANDSCAPED AREAS
COVER > 0.9m

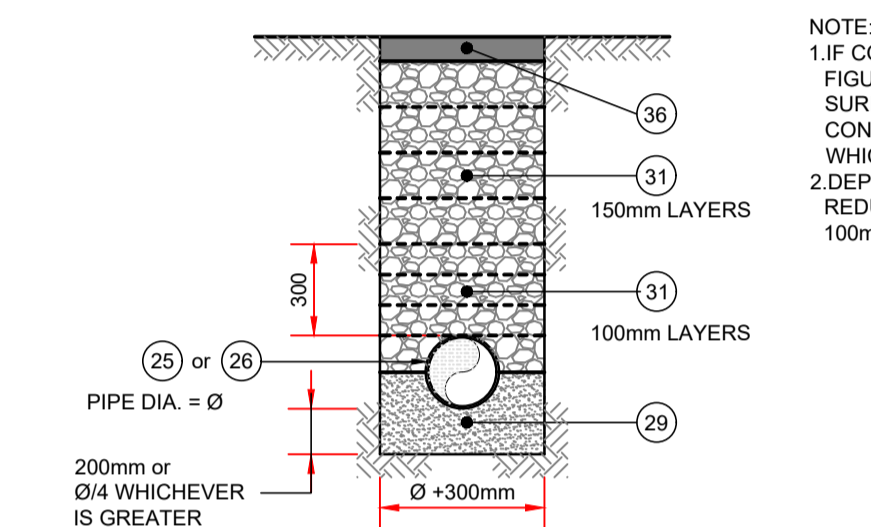

UNDER ROADS/HARDSTANDINGS/FOOTPATHS
COVER > 1.2m



GRANULAR BEDDING

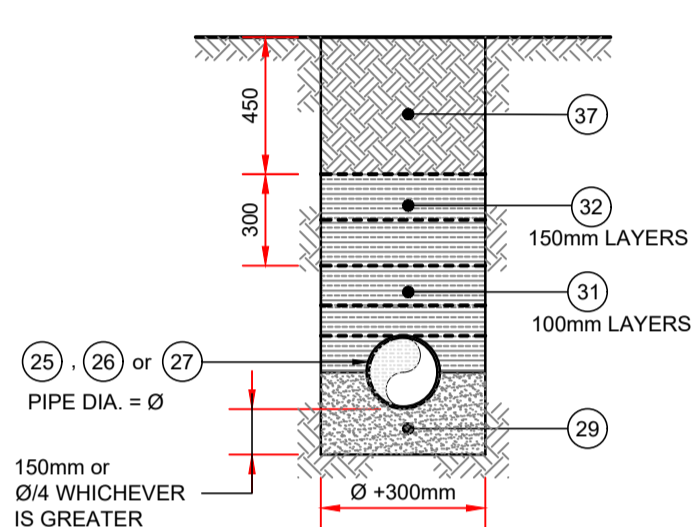

UNDER LANDSCAPED AREAS
COVER > 0.9m

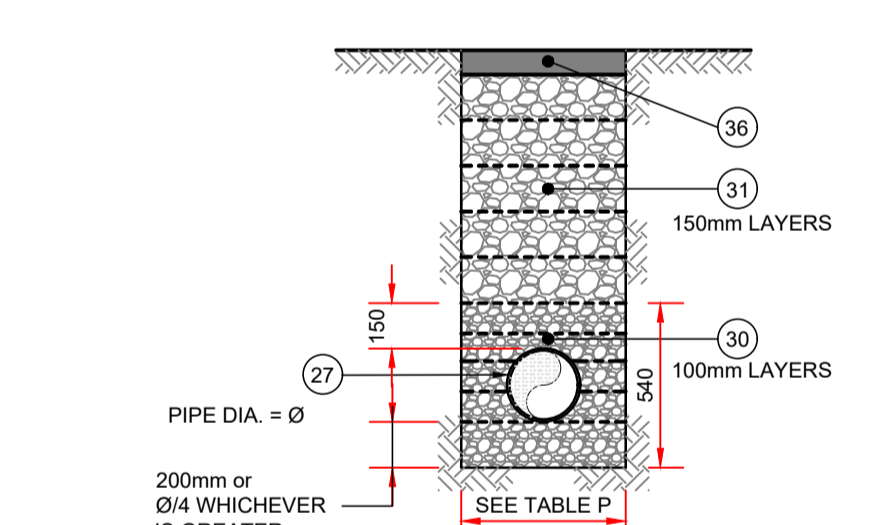

UNDER ROADS/HARDSTANDINGS/FOOTPATHS
COVER > 1.2m

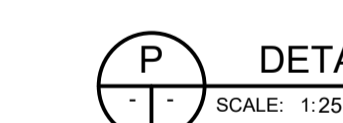

UPVC PIPES BEDDING

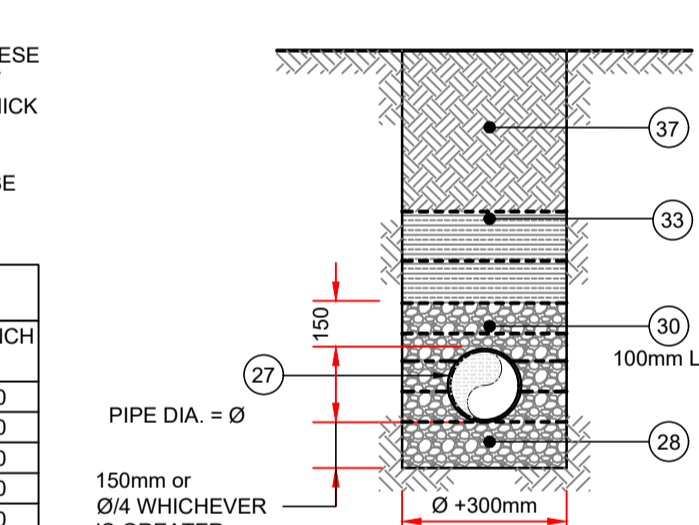

UNDER LANDSCAPED AREAS
COVER > 1.2m



NOTE: 1. IF COVER IS LESS THAN THESE FIGURES PIPE TO BE FULLY SURROUNDED IN 150mm THICK CONCRETE AS PER DETAIL Q0/4 WHICH EVER IS GREATER. 2. DEPTH OF BEDDING CAN BE REDUCED TO 100mm FOR 100mm Ø PIPES.

PIPE SIZE (mm)	WIDTH OF TRENCH (mm)
110	450
160	450
200-250	600
315	700
355	750
400	800
450	850

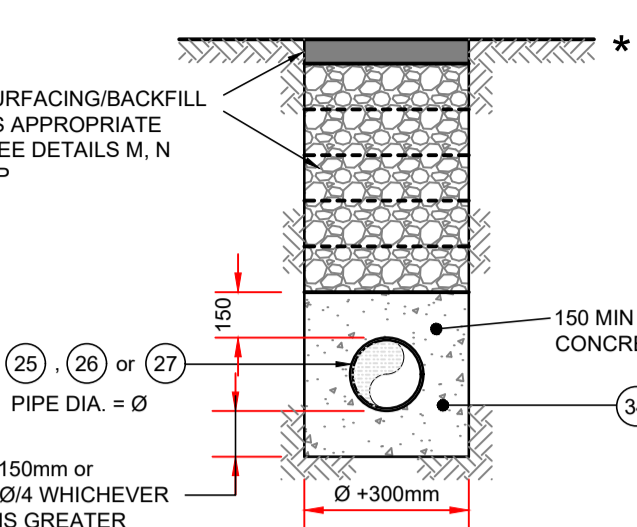

CONCRETE PIPE ENCASEMENT

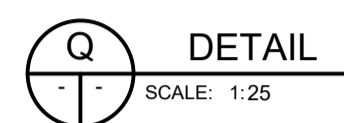

CONCRETE ENCASEMENT

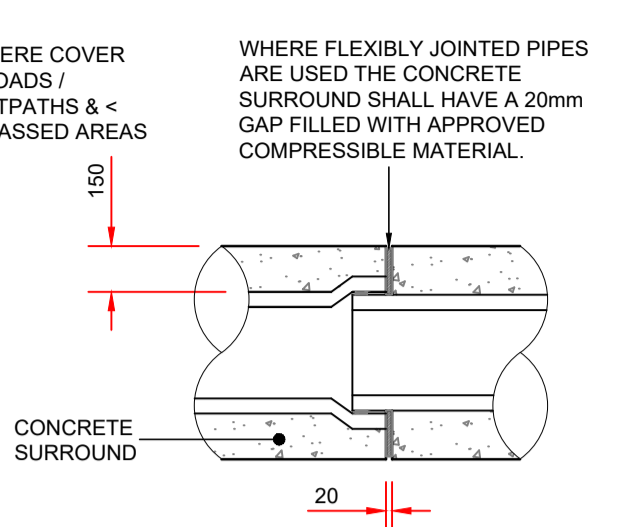

JOINT IN CONCRETE SURROUND

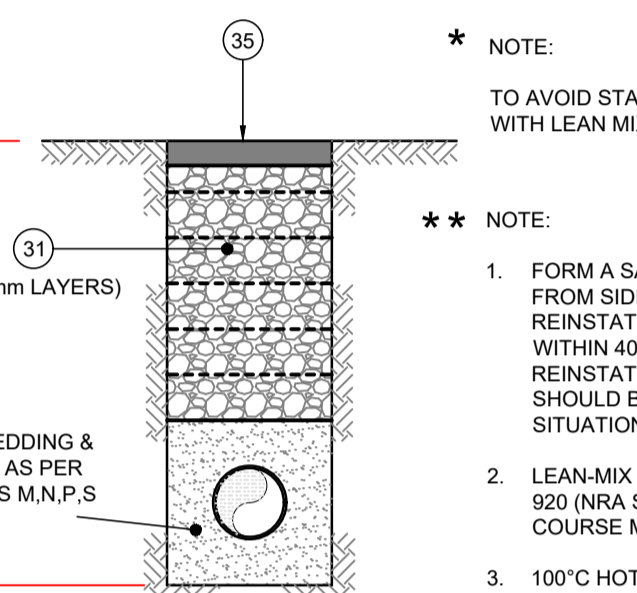

STAGE 1
LEAVE FOR 6 MONTHS TO CONSOLIDATE



REINSTATEMENT OF PIPE TRENCH IN EXISTING ROAD

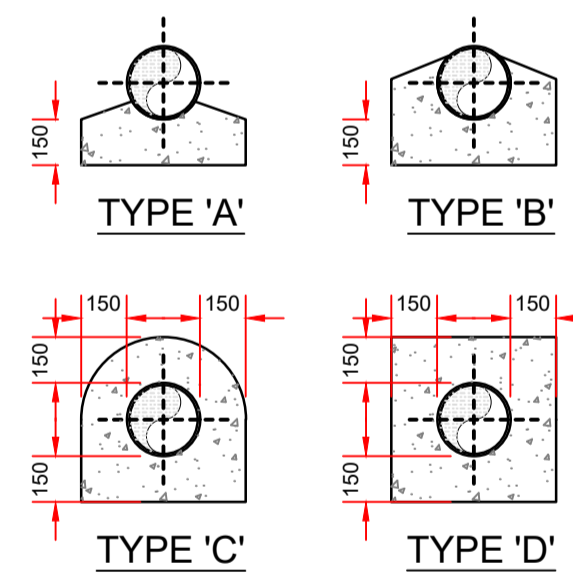

- GENERAL NOTES
- IN SOFT CONDITIONS CBR<5 THE MATERIAL SHOULD BE EXCAVATED AND DISPOSED IN ACCORDANCE WITH THE WASTE MANAGEMENT ACT AND CLAUSE 804 MATERIAL IN ACCORDANCE WITH THE NRA SPECIFICATION FOR ROAD WORKS. SHALL REPLACE THE EXCAVATED MATERIAL WRAPPED IN GEO-TEXTILE SHEETING. ALTERNATIVELY SPECIAL PIPE SUPPORT ARRANGEMENTS INCLUDING PILING ETC. MAY BE REQUIRED WHERE THE SOFT MATERIAL IS EXCESSIVE. SUCH ARRANGEMENTS SHALL BE ASSESSED BY IRISH WATER BEFORE ADVANCING WITH THE WORK.
 - PIPES SHALL NOT BE SUPPORTED ON STONES, ROCKS OR HARD OBJECT AT ANY POINT ALONG THE TRENCH. ROCK SHALL BE EXCAVATED TO A DEPTH OF 150mm BELOW THE ACTUAL DEPTH OF THE TRENCH WITH THE VOID FILLED WITH CLAUSE 804 MATERIAL. IN ACCORDANCE WITH THE NRA SPECIFICATION FOR ROAD WORKS. THE GRANULAR MATERIAL SHALL BE LAID ABOVE THIS VOID BACKFILL MATERIAL.
 - NON DEGRADABLE MARKER TAPE SHOULD BE INSTALLED AT TOP OF PIPE BEDDING LAYER. IN CASE OF NON METAL PIPE MATERIAL THE MARKER SHOULD INCORPORATE A TRACE WIRE WHICH IS LINKED TO THE FITTINGS AND TERMINATED AT THE PLUMBING STATION AND DISCHARGE MANHOLE.
 - TRENCH WIDTHS FOR PIPE SIZES 80mm AND LESS MAY BE <50mm SUBJECT TO CONSIDERATION BEING GIVEN TO THE TRENCH DEPTH, H&S, CONSTRUCTION ACCESS REQUIREMENTS.
 - THE HAUNCHES AND SURROUNDS TO BE FORMED USING FORM WORK AND PROVIDE A ROUGH CAST.
 - EXPANSION JOINTS IN THE CONCRETE SHALL BE PROVIDED AT ALL PIPE JOINTS TO ALLOW FOR PIPE FLEXIBILITY. COMPRESSIBLE FILLER BOARD TO BE IN ACCORDANCE WITH BS EN 622-1 AND BS EN 622-4 AND TO BE 18mm THICK.
 - POLYETHYLENE PIPES SHALL BE WRAPPED IN PLASTIC SHEETING HAVING A COMPOSITION IN ACCORDANCE WITH BS 6076 BEFORE BEING CAST INTO CONCRETE.
 - BITUMINOUS MATERIAL SHALL NOT BE PUT IN CONTACT WITH PE OR PVC PIPES.

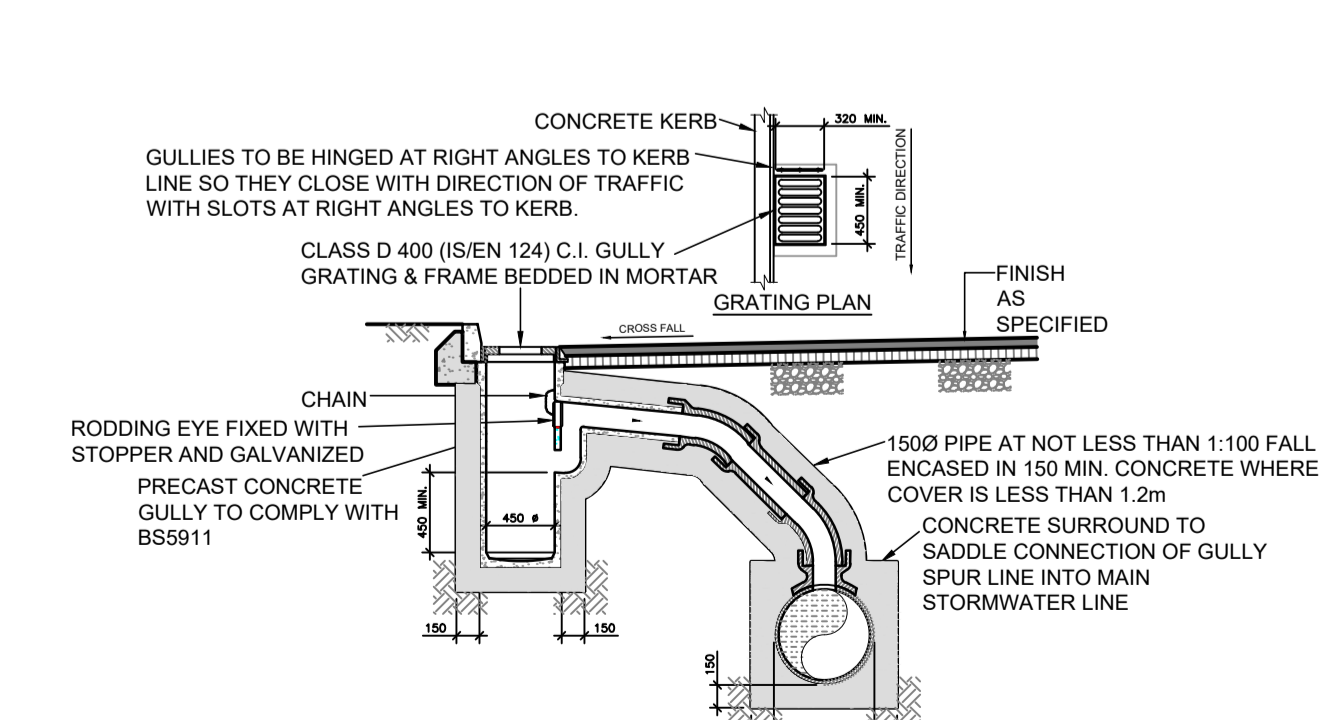

PRECAST ROAD GULLY DETAILS
A1 SCALE 1:50
A3 SCALE 1:100

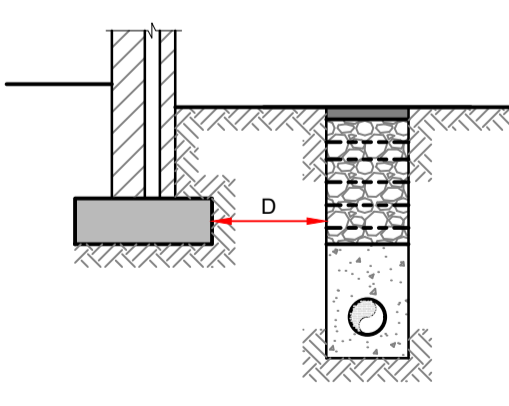

WHERE 'D' IS LESS THAN 1m
CONCRETE FILL TO LEVEL OF FOUNDATION BOTTOM

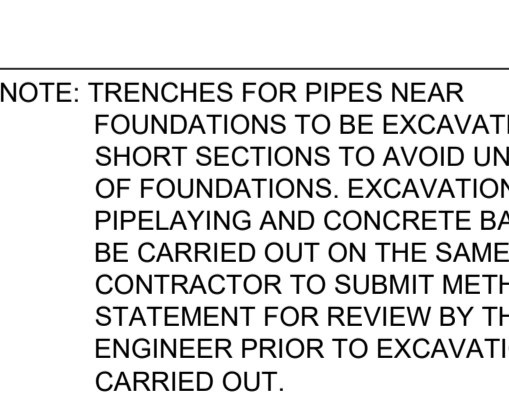

WHERE 'D' IS 1m OR MORE
CONCRETE FILL TO WITHIN D-150mm OF LEVEL OF FOUNDATION BOTTOM



CONCRETE PIPE LAID NEAR FOUNDATIONS

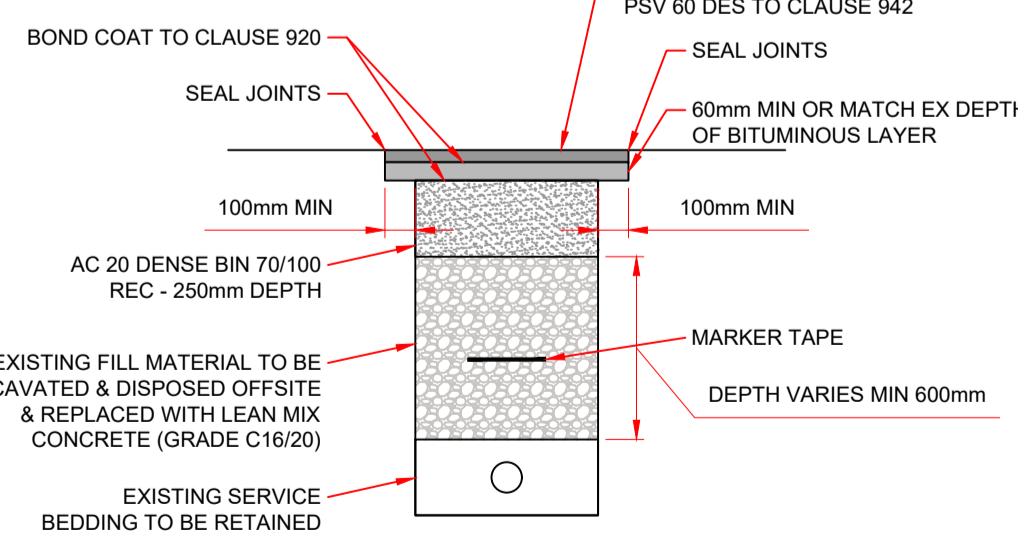

TYPICAL SERVICE REINSTATEMENT
DETAIL - ASPHALT ROAD



CONCRETE PIPE ENCASEMENT

- NOTES:
- 225mm THICK C30/37 MASS CONCRETE FOUNDATIONS.
 - PREFORMED HALF CIRCLE CHANNEL PIPES. THE PIPELINE MAY, WHERE PRACTICABLE BE LAID THROUGH THE MANHOLE & THE CROWN CUT OUT TO HALF DIAMETER. PROVIDED FLEXIBLE JOINTS ARE SITUATED ON EACH SIDE NO FURTHER THAN 600mm FROM INNER FACE OF THE MANHOLE WALL.
 - MANHOLE CONSTRUCTION:
 - FOR SURFACE WATER MANHOLES HIGH-DENSITY BLOCKS 20N STRENGTH TO IS EN 771 OR C30/37 INSITU CONCRETE TO IS EN 206.
 - BLOCK WORK SHALL BE EMBEDDED & JOINTED USING MORTAR TO IS 406. BEDS & VERTICAL JOINTS TO BE COMPLETELY FILLED WITH MORTAR AS THE BLOCKS ARE LAID.
 - ALL FOUL MANHOLES MUST BE FACED IN SOLID ENGINEERING BRICK (MIN CLASS 'A' OR 'B') OR INSITU CONCRETE FOR 1m ABOVE BENCHING LEVEL. BRICK TO BE BONDED TO BLOCK WORK USING GARDEN WALL BOND.
 - JOINTS SHALL BE FLUSH AND POINTED AS THE WORK PROCEEDS.
 - MAX DEPTH OF BLOCKWORK MANHOLE IS 1.2m (THE USE OF BLOCK IN DEEPER MANHOLES WILL BE CONSIDERED BUT SUCH WILL REQUIRE DETAILED STRUCTURAL DESIGN AND WRITTEN APPROVAL FROM IRISH WATER.
 - RELIEVING ARCH FORMED BY 215 X 103 X 65 SOLID ENGINEERING BRICK CLASS 'A' OR 'B'. RELIEVING ARCHES USED IN BRICK OR BLOCK WORK MANHOLES EXTEND OVER FULL THICKNESS OF WALL A DOUBLE ARCH IS TO BE FORMED FOR PIPE DIAMETER GREATER THAN 600mm.
 - BENCHING & PIPE SURROUND - C30/37 CONCRETE.
 - BENCHING FINISHED IN SAND-CEMENT MORTAR WITH SMOOTH TOWEL FINISH. AT 1 IN 30 SLOPE TOWARDS CHANNEL.
 - STANDARD RUNGS AT 300mm c/c VERTICALLY & GALVANISED TO THE LATEST VERSION OF BS 729 OR EQUIVALENT. NOTE IRONS ARE NOT ACCEPTABLE.
 - 600mm SQUARE OPE IN ROOF.
 - PRECAST R C ROOF SLAB SHALL BE 200mm THICK CLASS C30/37 WITH 40mm COVER TO STEEL DESIGNED TO BS 8100 TO TAKE FULL TRAFFIC LOADING.
 - 1 TO 2 COURSES OF SOLID ENGINEERING BRICKS CLASS 'B' TO IS 91.1983 SET IN C50/60 MORTAR.
 - CLASS D400 OR E600 MANHOLE COVER AND FRAME TO IS EN 124. 150mm DEEP FRAME FOR ROADS & 100mm DEEP FOR FOOTPATHS & GREEN AREAS. NON-ROCK DESIGN. CLOSED KEYWAYS, MANUFACTURED FROM SPHERICAL GRAPHITE CAST IRON (DUCTILE CAST IRON) 600 X 600 (600X) CLEAR OPENINGS. COVER & FRAME COATED IN BITUMEN OR OTHER APPROVED MATERIAL. COVER TO HAVE MINIMUM MASS OF 140kg/M2 FRAME BEARING AREA SHALL BE DESIGNED TO PREVENT COVERS FALLING INTO MANHOLE. FRAMES SHALL BE BEDDED ON APPROVED MORTAR TO MANUFACTURERS INSTRUCTIONS.
 - SHORT LENGTH PIPE & PIPE JOINT EXTERNAL TO MANHOLE SHALL NOT EXCEED 600mm FROM THE INNER FACE OF MANHOLE WALL.
 - TOE HOLES OF 230mm MINIMUM DEPTH & GALVANISED SAFETY RAILINGS TO BE PROVIDED IN BENCHING OF SEWERS GREATER THAN 525mm Ø & DEPTH TO INVERT >3M FOR ACCESS TO INVERT.
 - A STAINLESS STEEL CHAIN IS TO BE PROVIDED ON PIPES THAT EXCEED 450mm Ø. COMPLYING WITH BS 4942 PART 2 OR EQUIVALENT.
 - WHEN THE DEPTH OF MANHOLES TO INVERT IS GREATER THAN 3.0m LADDERS SHALL BE USED. INSTEAD OF RUNGS TO BS 4211 OR EQUIVALENT EXCEPT THAT STRINGERS SHOULD BE NOT LESS THAN 65x12mm IN SECTIONS & RUNGS 25mm IN DIAMETER. FIXED LADDERS SHOULD MEET THE DIMENSIONAL REQUIREMENTS OF BS4211 OR EQUIVALENT. DISTANCE FROM THE TOP RUNG OF THE LADDER TO GROUND LEVEL SHOULD NOT EXCEED 500mm.
 - LADDER STRINGERS SHOULD BE ADEQUATELY SUPPORTED FROM THE MANHOLE WALL AT INTERVALS OF NOT MORE THAN 2.0m. STRINGERS SHOULD BE BOLTED TO CLEATS TO FACILITATE RENEWAL.
 - ALL LADDER RUNGS, HANDRAILS, SAFETY CHAINS ETC. SHALL BE HOT DIPPED GALVANISED TO BS 729 OR EQUIVALENT.
 - PIPE SHOULD BE CUT FLUSH WITH THE INSIDE SURFACE OF THE MANHOLE WALL SO THAT CHANNEL EXTENDS THE FULL LENGTH OF THE MANHOLE.
 - POSITION OF 910 SQUARE OPE IN INTERMEDIATE ROOF SLAB.
 - ALL MANHOLES SHALL BE WATERTIGHT TO THE SATISFACTION OF THE ENGINEER.
 - FOR WORK TO REINFORCED CONCRETE & MASS CONCRETE SHALL COMPLY WITH CLASS SECTION 6.2.7, BS 8110 PART 1:1987
 - FINISH TO THE TOP OF SLABS SHALL COMPLY WITH TYPE A SECTION 6.2.7, BS8110, PART 1997.
 - PLAN DIMENSIONS OF MANHOLES ARE BASED ON BLOCKWORK HAVING A CO-ORDINATING SIZE OF 450 X 225 X 100. FORT PIPE DIAMETER OF >750mm USE MANHOLE WITH INTERNAL DIAMETER SIZE = PIPE SIZE +1m +300mm
 - MANHOLES ARE DESIGNED TO BS8005 & WALL THICKNESS TO IS325. BLOCK WORK DESIGN CODE TAKING GRANULAR FILL PRESSURE & H B SURCHARGE.
 - REINFORCEMENT TO SLABS ENGINEERS DETAILS.
 - FOR MANHOLES >3m DEPTH TO INVERT USE C30/37 INSITU CONCRETE. REINFORCING MESH REF. A393 TO BE FIXED AT MID POINT OF WALL. ADDITIONAL REINFORCEMENT TO BE SUPPLIED OVER PIPE CROWN.
 - PRECAST MANHOLES, CHAMBER WALLS & COVER SLAB TO BE CONSTRUCTED TO IS EN 1917 & IS 420:2004
 - MANHOLE OPENINGS TO BE SITUATED FURTHEST FROM THE NEAREST CARRIAGEWAY. MANHOLE STEPS-ACCESS TO BE POSITIONED TO ALLOW VIEWING OF ONCOMING TRAFFIC
 - FOR BEDDING & SEALING OF CHAMBER RINGS, THE TOP RING (TO PRECAST OVER SLAB) & BOTTOM RING TO BE BEDDED WITH CEMENT MORTAR. FOR INTERMEDIATE RINGS, JOINTS TO BE SEALED WITH APPROVED PREFORMED JOINTING STRAP
 - PRECAST MANHOLES TO BE SURROUNDED WITH A MINIMUM OF 150mm THICK GRADE C16/20 CONCRETE.
 - CONCRETE SEWER PIPES WITH SPIGOT & SOCKET JOINTS & RUBBER FITTINGS TO COMPLY WITH IS EN 1916 & IS 6 2004 OR EQUIVALENT STANDARD CLASS M OR CLASS H
 - VERTIFIED CLAY PIPES AND FITTINGS COMPLYING WITH THE REQUIREMENTS OF IS EN 295-1/2/3 : 1992 OR EQUIVALENT STANDARD CLASS 160 OR CLASS 200
 - UNPLASTICISED POLYVINYL CHLORIDE (UPVC) PIPES & FITTINGS IN ACCORDANCE WITH THE REQUIREMENTS OF IS424
 - CONCRETE BED & SURROUND MUST BE A MINIMUM 150mm THICK IN-SITU CONCRETE C16/20 & HAUNCHED HALFWAY UP THE BARREL OF THE PIPE.
 - GRANULAR BED AND SURROUND OF RIGID PIPES TO BE EITHER
 - 14mm TO 5mm GRADED AGGREGATE OR
 - 10mm SINGLE SIZE AGGREGATE
 - GRANULAR BED AND SURROUND & COVER FOR UPVC TO BE:
 - 14mm TO 5mm GRADED AGGREGATE 315mm+ PIPE DIAMETER
 - 10mm SINGLE SIZED AGGREGATE PIPE DIAMETER <315mm

- 31) GRANULAR BACKFILL MATERIAL SHALL BE IN COMPLIANCE WITH CLAUSE 804 (GRANULAR MATERIAL TYPE B) OF THE NRA SPECIFICATION FOR ROAD WORKS. GRANULAR FILL SHOULD BE PLACED ON EITHER SIDE OF THE FILL IN UNIFORM LAYERS NOT EXCEEDING 100mm. EACH LAYER BEING COMPACTED BY HAND & UNDERGOING TAMPING UNTIL IT HAS A MINIMUM LAYER OF 300mm COMPACTED COVER CARE SHOULD BE TAKEN SO THAT THE TAMPING DOES NOT DISPLACE THE PIPE FROM ITS CORRECT LINE AND LEVEL. SUBSEQUENT LAYER OF GRANULAR MATERIAL TO BE COMPACTED IN 150mm THICK LAYERS TO THE LOCAL AUTHORITY ROAD DIVISION SPECIFICATION. MECHANICAL COMPACTING EQUIPMENT SHOULD NOT BE USED UNTIL THERE IS A MINIMUM 450mm THICK COMPACTED COVER OVER THE CROWN OF THE PIPE.
- 32) SELECTED FILL SHOULD BE FREE FROM STONES LARGER THAN 37mm. LUMPS OF CLAY OVER 75mm, TIMBER, FROZEN MATERIAL & VEGETABLE OR FOREIGN MATTER. SELECTED FILL ON EITHER SIDE OF THE PIPE SHOULD BE LAID IN 100mm THICK LAYERS. EACH LAYER BEING COMPACTED BY HAND & UNDERGOING TAMPING UNTIL IT HAS A MINIMUM LAYER OF 450mm COMPACTED COVER CARE SHOULD BE TAKEN SO THAT THE TAMPING DOES NOT DISPLACE THE PIPE FROM ITS CORRECT LINE AND LEVEL & COMPACTED IN 150mm LAYERS.
- 33) GENERAL BACKFILL MATERIAL SUITABLE FOR BACKFILL ABOVE SELECTED FILL MATERIAL SHOULD BE FREE FROM BOULDERS, LUMPS OF CONCRETE, TIMBER & VEGETABLE OR FOREIGN /CONTAMINATED MATTER. GENERAL BACK FILL SHOULD BE PLACED IN LAYERS NOT EXCEEDING 300mm. EACH LAYER BEING WELL COMPACTED. MECHANICAL COMPACTING EQUIPMENT SHOULD NOT BE USED UNTIL THERE IS MINIMUM OF 450mm COMPACTED COVER OVER THE CROWN OF THE PIPE.
- 34) PIPES WITH INADEQUATE COVER TO BE SURROUNDED IN 150MM THICK C16/20 CONCRETE.
- 35) LEAN MIX BACKFILL IN EXISTING ROADS, WHERE REQUIRED BY THE LOCAL AUTHORITY TO BE GRADE 20N/20MM CONCRETE.
- 36) PAVING TO BE IN ACCORDANCE WITH THE ROAD SPECIFICATION & IF APPROPRIATE, THE LOCAL AUTHORITY REQUIREMENTS.
- 37) GOOD QUALITY TOPSOIL 450mm MINIMUM THICKNESS. TO BE PLACED OVER BACKFILL IN ACCORDANCE WITH PARKS DEPARTMENT/ LANDSCAPE ARCHITECTS.
- 38) A/J's (ARMSTRONG JUNCTIONS)
 - TO BE USED FOR PIPE DEPTHS UP TO 600mm
 - INTERNAL A/J'S IF REQUIRED TO HAVE DOUBLE SEALED COVERS
 - EXTERNAL A/J'S TYPICALLY TO BE PROPRIETARY UPVC WITH 35N COVER
 - EXTERNAL A/J'S IN AREAS SUBJECT TO TRAFFIC TO BE SURROUNDED IN 150mm C20 CONCRETE & TO HAVE CLASS D COVER AND FRAME SUPPORTED OF THE CONCRETE SURROUND.

- NOTES:
- FIGURED DIMENSIONS ONLY TO BE TAKEN FROM THIS DRAWING
 - ALL DRAWINGS TO BE CHECKED BY THE CONTRACTOR ON SITE.
 - ENGINEER/EMPLOYERS REPRESENTATIVE, AS APPROPRIATE, TO BE INFORMED BY THE CONTRACTOR OF ANY DISCREPANCIES BEFORE ANY WORK COMMENCES.
 - THE CONTRACTOR SHALL UNDERTAKE A THOROUGH CHECK FOR THE ACTUAL LOCATION OF ALL SERVICES/UTILITIES, ABOVE AND BELOW GROUND, BEFORE ANY WORK COMMENCES.
 - ALL LEVELS SHOWN RELATE TO ORDINANCE SURVEY DATUM AT MALIN HEAD.

Rev	Date	Description	By	Chkd.
PO-1	07.08.2024	ISSUE FOR PLANNING	GM	MG

Client: Comhairle Chontae na Gaillimhe Galway County Council

Project: Loughrea Fire Station

Title: Standard Pipe Bedding Details

Scale @ A1: As Shown

Prepared by: GM Checked: MG Date: Aug 2024

Project Director: Brian Carroll

Drawing Status: PLANNING

TOBIN
CONSULTING ENGINEERS

TOBIN Consulting Engineers, Fairgreen House, Fairgreen Road, Galway, Ireland.
Tel: +353 (0)91-565211
fax: +353 (0)91-565398
e-mail: galway@tobin.ie
www.tobin.ie

Revision: PO-1